

OPERATOR'S MANUAL

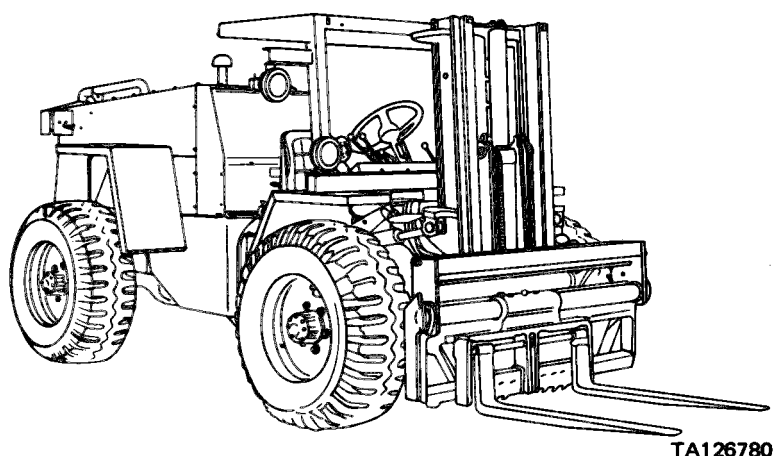

TRUCK, FORKLIFT, DED,
PNEUMATIC TIRE, ARTICULATED
FRAME STEER, 4,000 LB. CAPACITY
ROUGH TERRAIN, ARMY MODEL MHE 237
(J. I. CASE MODEL M4K)
(NSN 3930-01-076-4237)

This copy is a reprint which includes current
pages from Changes 1 and 2.

TABLE OF CONTENTS
PAGE I

GENERAL INFORMATION
PAGE 1-1

EQUIPMENT DESCRIPTION AND DATA
PAGE 1-3

PRINCIPLES OF OPERATION
PAGE 1-5

DESCRIPTION AND USE OF
OPERATOR'S CONTROLS AND
INDICATORS
PAGE 2-1

PREVENTIVE MAINTENANCE CHECKS
AND SERVICES (PMCS)
PAGE 2-9

OPERATION UNDER USUAL
CONDITIONS
PAGE 2-13

OPERATION UNDER UNUSUAL
CONDITIONS
PAGE 2-21

LUBRICATION INSTRUCTIONS
PAGE 3-1

OPERATOR/CREW TROUBLE-
SHOOTING PROCEDURES
PAGE 3-3

REFERENCES
PAGE A-1

COMPONENTS OF END ITEM LIST
PAGE B-1

ADDITIONAL AUTHORIZATION LIST
PAGE C-1

EXPENDABLE SUPPLIES AND
MATERIALS LIST
PAGE D-1

CHANGE
No. 2

HEADQUARTERS
DEPARTMENT OF THE ARMY
Washington D. C., 4 December 1990

OPERATOR'S MANUAL
TRUCK, FORKLIFT, DED, PNEUMATIC TIRE,
ARTICULATED FRAME STEER,
4,000-LB. CAPACITY, ROUGH TERRAIN
ARMY MODEL MHE 237
(NSN 3930-01-076-4237)

TM 10-3930-638-10, 30 May 1980, is changed as follows:

1. Remove old pages and insert new pages.
2. New or changed material is indicated by a vertical bar in the margin of the page and by a vertical bar adjacent to the TA number.

Remove Pages

1-9 and 1-10
2-9 through 2-12

Insert Pages

1-9 and 1-10
2-9 through 2-12

3. File this change sheet in front of the publication for reference purposes.

By Order of the Secretary of the Army:

CARL E. VUONO
General, United States Army
Chief of Staff

Official:

THOMAS F. SIKORA
Brigadier General, United States Army
The Adjutant General

Distribution:

To be distributed in accordance with DA Form 12-25-E (Block 2161) Operator maintenance requirements for TM10-3930-638-10.

CHANGE

NO. 1

HEADQUARTERS
DEPARTMENT OF THE ARMY
Washington D.C., 14 March 1990

OPERATOR'S MANUAL
TRUCK, FORKLIFT, DED, PNEUMATIC TIRE,
ARTICULATED FRAME STEER,
4,000-LB. CAPACITY, ROUGH TERRAIN,
ARMY MODEL MHE 237
(NSN 3930-01-076-4237)

TM 10-3930-638-10, 30 May 1980, is changed as follows:

1. Remove old pages and insert new pages.
2. New or changed material is indicated by a vertical bar in the margin of the page and by a vertical bar adjacent to the TA number.

Remove Pages

A and B
i and 1-0
1-1 and 1-2
1-7 through 1-10
2-9 through 2-12
2-17 and 2-18
A-1(A-2 blank)
C-1(C-2 blank)
D-1(D-2 blank)

Insert Pages

A and B
i and 1-0
1-1 and 1-2
1-7 through 1-10.2
2-9 through 2-12
2-17 and 2-18
A-1(A-2 blank)
C-1(C-2 blank)
D-1(D-2 blank)

3. File this change sheet in front of the publication for reference purposes.

By Order of the Secretary of the Army:

Official:

CARL E. VUONO
General, United States Army
Chief of Staff

WILLIAM J. MEEHAN II
Brigadier General, United States Army
The Adjutant General

Distribution:

To be distributed in accordance with DA Form 12-25F (Block 2161) Operator maintenance requirements for Fork Lift, 4000 LB Capacity, Rough Terrain, Pneumatic Tire, Articulated Frame Steer (Model MHE-237).

WARNING

FIRE HAZARD

Diesel fuel used in operation of this equipment is combustible.

WARNING

**HYDRAULIC OIL UNDER PRESSURE
2500 PSI PRESSURE**

is used in the operation of this equipment.

WARNING

ELECTRICAL SHOCK HAZARD

Always disconnect battery ground cable before working on electrical components of this equipment.

WARNING

TIRE INFLATION

Observe caution when inflating tires.

Make sure tires are properly seated on rims before inflating.

Improperly seated tires can burst with explosive force sufficient to cause death.

WARNING

DANGEROUS CHEMICALS

Battery electrolyte is toxic and corrosive!

Use protective goggles and gloves.

Avoid contact with skin, eyes, clothes and don't breathe vapors.

WARNING

EXHAUST GASES CAN BE DEADLY

Exhaust gases can produce symptoms of headache, dizziness, loss of muscular control, or coma.

Permanent brain damage or death can result from severe exposure.

You can insure your safety by following these rules:

DON'T operate the heater or engine in an enclosed area unless it is properly ventilated.

DON'T drive with any of the truck's inspection plates, cover plates, or the hood off unless necessary for maintenance.

If you notice exhaust odors or exposure symptoms, IMMEDIATELY VENTILATE the area.

If the symptoms persist, remove the affected people and treat them:

- Expose them to fresh air.
- If necessary, give artificial respiration.
- Keep them warm.
- DON'T permit physical exercise.

Refer to FM 21-11, First Aid for Soldiers, for first aid treatment of injured personnel.

WARNING

NOISE HAZARD

Noise level exceeds 85 dB(A) at three feet in front, 15 feet at side,
and 24 feet at rear of vehicle.

All personnel shall wear a hearing protection device when operating the vehicle.

WARNING

Be sure your, seat belt is fastened before starting engine and operating the vehicle.

WARNING

Be sure that steering bypass valve is closed (fully clockwise) and that shipping lock pin is removed before operating vehicle.
Failure to do so will cause loss of steering control, which may result in death or serious injury.

WARNING

Always operate vehicle at a safe speed. Avoid overloading and sudden stops. Caution is advised when operating on a slope with any load. Do not tilt load out beyond vertical position of mast when elevated unless load is over a stack.

WARNING

Starting fluid is toxic and highly flammable. Container is pressurized to act as an expellent. Don't heat container and don't discharge starting fluid in confined areas or near an open flame. Don't discard used container in an open flame.

WARNING

Dry cleaning solvent P-D-680 used to clean parts is potentially dangerous to personnel and property. Do not use near open flame or excessive heat. Flash point of solvent is 138 degrees F.

OPERATORS MANUAL

TRUCK, FORKLIFT, DED, PNEUMATIC TIRE, ARTICULATED
FRAME STEER, 4,000-LB. CAPACITY, ROUGH TERRAIN,
ARMY MODEL MHE 237
(NSN 3930-01-076-4237)

REPORTING ERRORS AND RECOMMENDING IMPROVEMENTS

You can help improve this manual. If you find any mistakes or if you know of a way to improve the procedures, please let us know. Mail your letter, DA Form 2028 (*Recommended Changes to Publications and Blank Forms*), or DA Form 2028-2, located in the back of this manual, direct to: Commander, U.S. Army Tank-Automotive Command, ATTN: AMSTA-MB, Warren, MI 48397-5000. A reply will be furnished to you.

		Page
CHAPTER 1	INTRODUCTION	1-1
	Chapter Overview	1-1
Section I	General Information	1-1
Section II	Equipment Description and Data	1-3
Section III	Principles of Operation	1-5
CHAPTER 2	OPERATING INSTRUCTIONS	2-1
	Chapter Overview	2-1
Section I	Description and Use of Operator's Controls and Indicators	2-1
Section II	Preventive Maintenance Checks and Services (PMCS)	2-9
Section III	Operation Under Usual Conditions	2-13
Section IV	Operation Under Unusual Conditions	2-21
CHAPTER 3	OPERATOR/CREW MAINTENANCE INSTRUCTIONS	3-1
	Chapter Overview	3-1
Section I	Lubrication Instructions	3-1
Section II	Operator/Crew Troubleshooting Procedures	3-3
APPENDIX A	REFERENCES	A-1
APPENDIX B	COMPONENTS OF END ITEM LIST	B-1
APPENDIX C	ADDITIONAL AUTHORIZATION LIST	C-1
APPENDIX D	EXPENDABLE SUPPLIES AND MATERIALS LIST	D-1

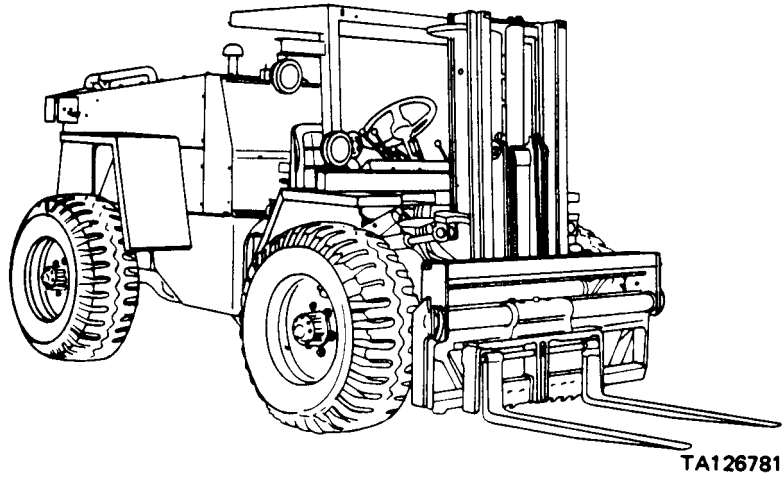

Right Front View

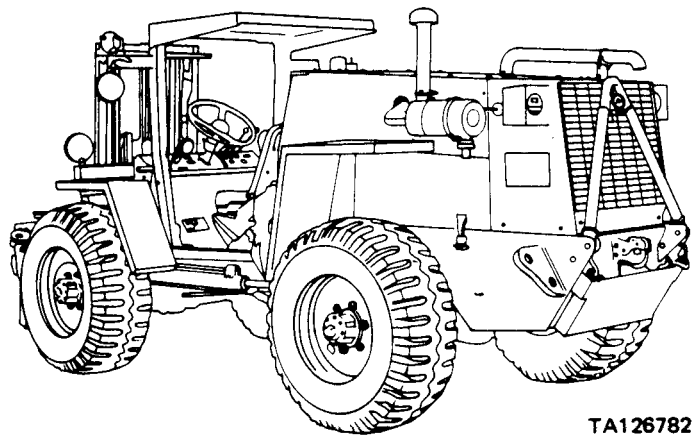

Left Rear View

MHE 237 forklift truck

CHAPTER 1 INTRODUCTION

CHAPTER OVERVIEW

The purpose of this chapter is to acquaint you with the maintenance forms, records, and reports that you must maintain for the forklift truck, to familiarize you with the purpose and capabilities of the forklift truck and to give you a brief description of the different systems and components of the forklift truck.

Index

Section	Title	Page
I	General Information	1-1
II	Equipment Description and Data	1-3
III	Principles of Operation	1-5

Section I. GENERAL INFORMATION

	Para		Para
Scope	1-1	Warranty Information	1-4
Maintenance Forms, Records and Reports	1-2	Orientation	1-5
Reporting Equipment Improvement Recommendations (EIR's)	1-3	List of Abbreviations	1-6

1-1. SCOPE

a. Type of Manual. Operator's Technical Manual, including operating and troubleshooting instructions.

NOTE

A waterproof cloth container is attached to the rear of the operator's seat. This container has two compartments: one compartment contains the vehicle log book and the other compartment provides storage for the operator's manual.

b. Model Number and Equipment Name. MHE 237 Rough Terrain 4,000 Pound Capacity, Articulated Frame Steer, Pneumatic Tire, Diesel Engine Driven Forklift Truck.

c. Purpose of Equipment. Handle, transport, and stack materials on various types of terrain. The forklift truck has a capacity of 4,000 pounds at 24-inch load center and can lift the load to a maximum height of 100-inches

1-2. MAINTENANCE FORMS, RECORDS AND REPORTS

Department of the Army forms and procedures used for equipment maintenance will be those prescribed by DA Pam 738-750, The Army Maintenance Management System.

1-3. REPORTING EQUIPMENT IMPROVEMENT RECOMMENDATIONS (EIR's)

You can help improve this manual. If you find any mistakes or if you know of a way to improve the procedures, please let us know. Mail your letter, DA Form 2028 (Recommended Changes to Publications and Blank Forms), or DA Form 2028-2, located in the back of this manual, direct to: Commander, U.S. Army Tank-Automotive Command, ATTN: AMSTA-MB, Warren, MI 48397-5000. A reply will be furnished to you.

1-4. WARRANTY INFORMATION

The model MHE 237 forklift truck is warranted by J. I. Case for 15 months or 1500 operating hours, whichever comes first. It starts on the date, found in block 23, DA Form 2408-9 in the logbook. Report all defects in material or workmanship to your supervisor, who will take appropriate action through your organizational maintenance shop.

1-5. ORIENTATION

The lifting forks are mounted on the front of the vehicle and the engine faces the rear. Controls for operating the

1-5. ORIENTATION (cont)

lifting forks (tilting, rotating, lowering, side shifting of the lifting forks) are located to the right when you're sitting in the operator's seat.

1-6. LIST OF ABBREVIATIONS

ABBREVIATION	DEFINITION
B.O.	Black out
C	Centigrade
CCW	Counterclockwise
CW	Clockwise
DA	Department of the Army
DED	Diesel engine driven
D.C.	District of Columbia
EA	Each
EIR	Equipment improvement recommendations
F	Forward
F	Fahrenheit
FWD	Forward
GAL	Gallon
In.	Inch
LB.	Pound

ABBREVIATION	DEFINITION
Lg	Long
MHE	Material handling equipment.
MI	Michigan
MPH	Miles per hour
MTOE	Modified table of organization and equipment
N	Neutral
NSN	National stock number
OZ	Ounce
Para	Paragraph
PMCS	Preventive maintenance checks and services
PRESS	Pressure
PSI	Pounds per square inch
QT	Quart
R	Reverse
ROPS	Roll Over Protective Structure
RPM	Revolutions per minute
SAE	Society of Automotive Engineers
SER.	Service
TEMP	Temperature
TRANS	Transmission

Section II. EQUIPMENT DESCRIPTION AND DATA

	Para
Equipment Purpose, Capabilities, and Features . .	1-7
Location and Description of Major Components	1-8
Equipment Data	1-9

1-7. EQUIPMENT PURPOSE, CAPABILITIES, AND FEATURES

a. *Purpose of Forklift Truck.* Handle, transport, and stack materials while operating over various types of terrain.

b. *Capabilities and Features.*

- (1) 4,000 pounds load capacity.
- (2) Operates over rough terrain.
- (3) Three speed ranges in both forward and reverse.

- (4) Declutch pedal to neutralize transmission.
- (5) Axle disconnect.
- (6) Diesel engine.
- (7) Power steering.
- (8) Power assisted brakes.
- (9) Articulated frame steering for operation within a 20 foot long by 8 foot wide by 8 foot high container.
- (10) Forks can be rotated and/or shifted left or right.
- (11) Mast can be tilted rearward or forward.

1-8. LOCATION AND DESCRIPTION OF MAJOR COMPONENTS

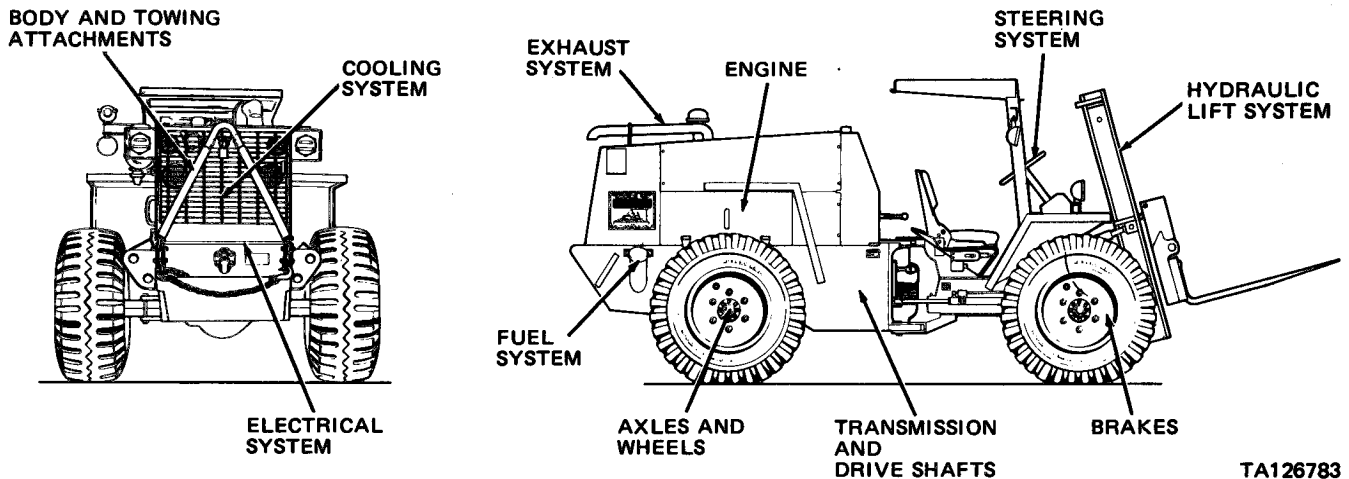

ENGINE. Four cylinder diesel.

FUEL SYSTEM. Consists of electric fuel pump, air cleaner, fuel tank, fuel filters, quick start kit, fuel injection pump, and fuel injectors.

EXHAUST SYSTEM. Consists of muffler and exhaust pipe; muffler mounted on top of engine and is of the spark arresting type.

COOLING SYSTEM. Includes radiator mounted in rear of truck, thermostat and housing, engine driven water pump, and fan.

ELECTRICAL SYSTEM. 24 Volt, negative ground. Includes engine driven alternator, starter motor, instrument panel, light system, and two 12 Volt batteries connected in series.

TRANSMISSION AND DRIVE SHAFTS. Three speeds in both forward and reverse, has declutch feature which permits neutralizing transmission, equipped with axle disconnect. Three drive shafts used to transmit power to front and rear axles.

AXLES AND WHEELS. Single reduction type axles; pneumatic tires.

BRAKES. Hydraulic operated service brakes and power assisted on all wheels; lever operated parking broke located on transmission output shaft.

STEERING SYSTEM. Consists of steering wheel, steering gear, two steering cylinders, and hydraulic pump driven by transmission.

1-8. LOCATION AND DESCRIPTION OF MAJOR COMPONENTS (cont)

HYDRAULIC LIFT SYSTEM. Includes control valve, mast column, hydraulic reservoir, and cylinders (tilt, rotation, side shift, and lift).

BODY AND TOWING ATTACHMENTS. Two section body consisting of front and rear chassis; towing attachments include pintle hook, tow bar and two chains all located at rear of truck.

1-9. EQUIPMENT DATA

Manufacturer J. I. Case
 Model M4K
 Dimensions and Weight
 Length (overall, mast vertical) 205 inches
 Length (overall, forks removed) 165 inches
 Height (overall, mast raised) 129.5 inches
 Height (overall, mast lowered, no ROPS) 78 inches
 Maximum height for shipping 80 inches
 Height to top of exhaust 71 inches
 Height to top of ROPS 80 inches
 Height to top of steering wheel 62 inches
 Ground clearance at mast (loaded). 10 inches
 Ground clearance at center 13.5 inches
 Wheelbase 92 inches
 Tire Tread 63 inches
 Width over tires 79 inches
 Angle of approach (forks raised and mast tilted back) 26 degrees
 Angle of Departure 34 degrees
 Pintle hook height (center). 31.8 inches
 Rear axle oscillation - total 25 degrees
 Turning Radius (outside of tires) 26 feet, 8 inches
 Turning angle from center (left and right) 43 degrees
 Rear load retaining surface (including load backrest) 17.0 inches high x 36 inches wide

Weight

No load weight, less operator, with full tank 9725 pounds
 Front axle load 4685 pounds
 Rear axle load 5040 pounds
 Weight with 4000 pound load 13725 pounds
 Front axle load 10810 pounds
 Rear axle load 2915 pounds

Performance

Speeds (MPH)
 1st 3.3
 2nd 7.2
 3rd 20.2
 Lift capacity rated (at 24 inch center) 4000 pounds
 Maximum lift height (to bottom of forks; empty) 100 inches
 Drop below ground (bottom of forks) 4,0 inches
 Minimum lateral fork adjustment (on centers) 8 inches
 Maximum lateral fork adjustment . 30 inches
 Rate of lift at rated load 62 FPM
 Rate of lift empty 88 FPM
 Rate of drop at rated load 80 FPM
 Rate of drop empty 68 FPM
 Reach from centerline of drive wheels 31.75 inches
 Degrees tilt (mast centered)
 Forward 11 degrees
 Rearward 22 degrees
 Mast sideshift (right or left from center) 22 inches
 Rotation angle 22 degrees total

Capacities

Fuel tank 27 gallons
 Cooling system 4 gallons
 Hydraulic system 65 quarts
 Transmission, torque converter 22 quarts
 Engine crankcase 7 quarts
 Axles (each) 14 quarts

Section III. PRINCIPLES OF OPERATION

Fuel System	Para 1-10	Steering System	Para 1-14
Electrical System	1-11	Body, Towing Attachments, and	
Transmission Controls	1-12	Towing Controls	1-15
Brake System	1-13	Mast Assembly	1-16

1-10. FUEL SYSTEM

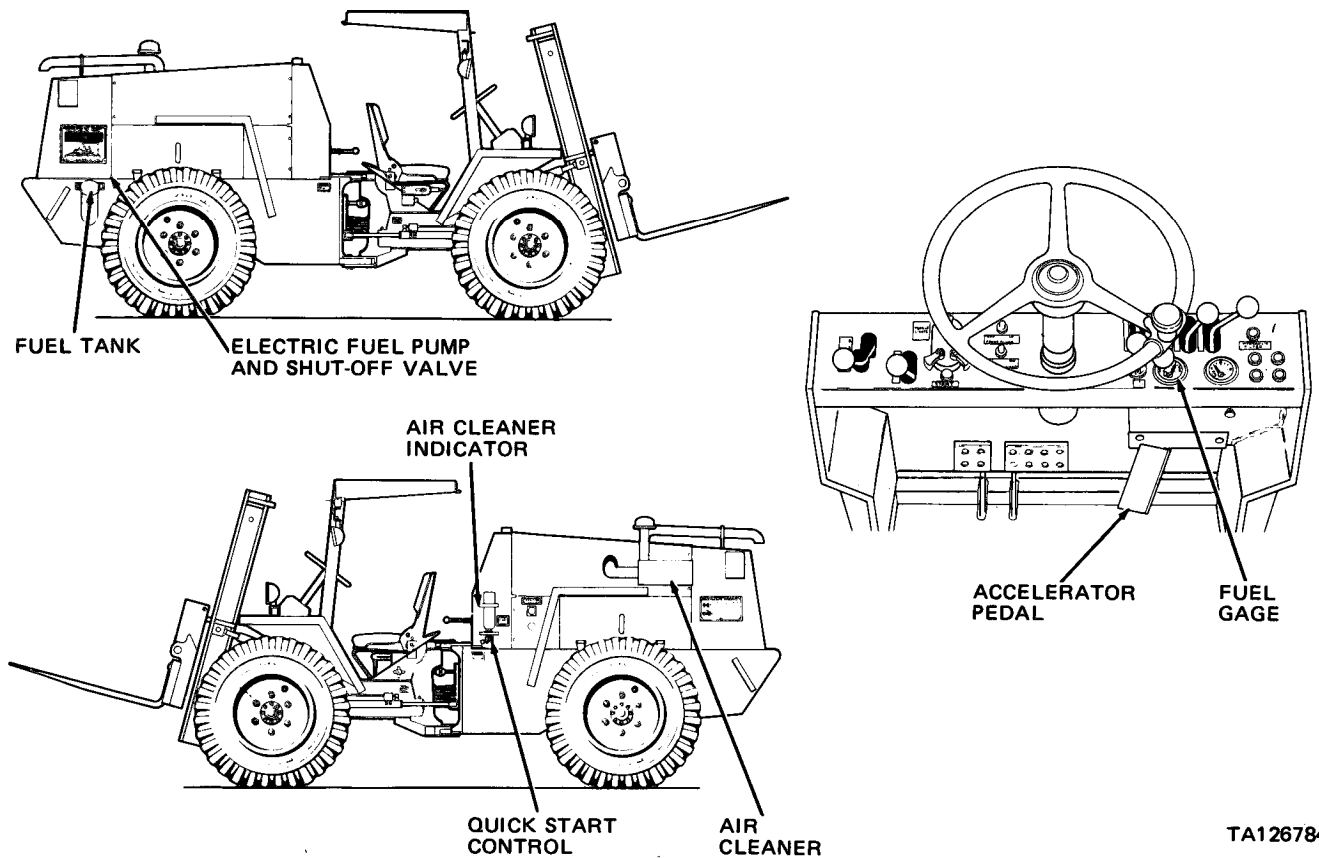

FUEL GAGE. Electrically operated meter type; calibrated in six gallon increments. With ignition switch key turned to ON position, fuel gage indicates quantity of fuel remaining in fuel tank.

ACCELERATOR PEDAL. Depressing pedal with foot increases fuel flow and engine speed; releasing pedal decreases fuel flow and engine speed. Pedal is spring loaded to return to low speed position when released.

FUEL TANK. Holds approximately 27 gallons of diesel fuel; constructed as part of rear chassis. Fuel filler neck and removable cap located at right rear of vehicle. A drain plug is located at the bottom of the tank.

ELECTRIC FUEL PUMP. Pumps diesel fuel from tank to engine. With ignition switch key turned to ON position, electric fuel pump will emit a slight buzz sound indicating proper operation.

SHUT-OFF VALVE. Located in right side of engine compartment above fuel filler neck. With valve handle in vertical position, blocks passage of diesel fuel from fuel tank to electric fuel pump. Valve handle must be in horizontal position to start and operate engine.

AIR CLEANER. Removes dust and dirt from air before air is applied to engine. Metal shell houses replaceable paper-type filter element.

1-10. FUEL SYSTEM (cont)

QUICK START CONTROL. Used to start engine in cold weather. When lever is pressed against valve, injects volatile starting fuel from steel cylinder to engine. Removable clip attaches to lever to prevent accidental discharge.

AIR CLEANER INDICATOR. Indicates restriction of air flow through air cleaner due to dirty or clogged filter element. Filter element service is required when red signal within indicator is in full view. After servicing filter element, indicator is reset by depressing button on top of indicator.

1-11. ELECTRICAL SYSTEM

a. Vehicle Lights.

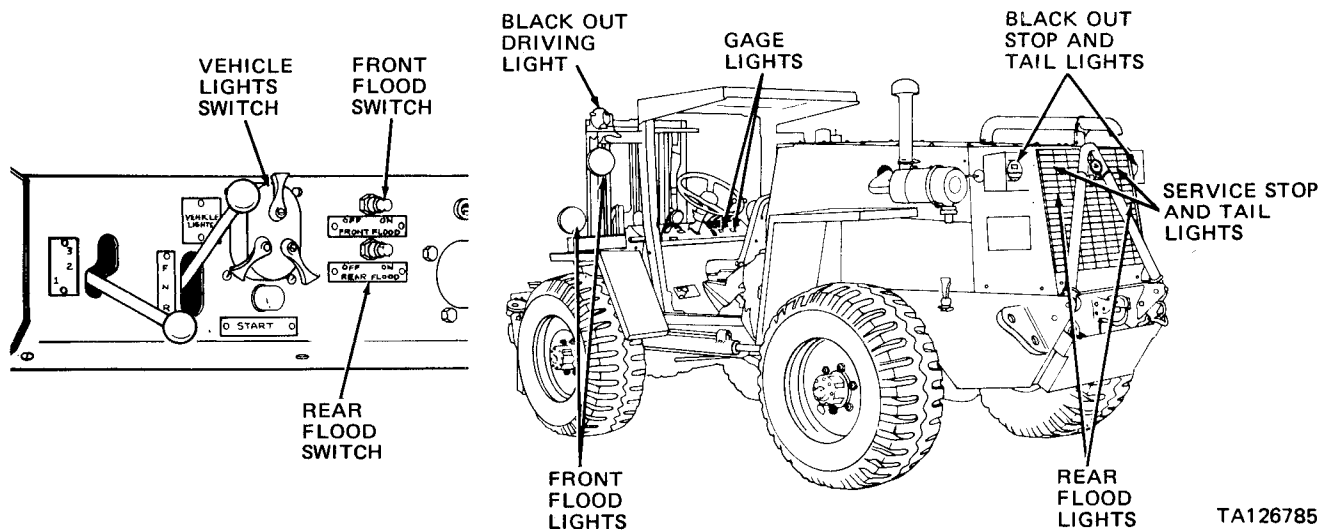

VEHICLE LIGHTS SWITCH. Contains three separate switch sections used to control all vehicle lights. Also has internal resistance to provide selection of dim illumination of gage lights. Ignition switch must be turned to extreme left or ON position for VEHICLE LIGHTS switch to operate.

FRONT FLOOD AND REAR FLOOD SWITCHES. Used to independently turn front and rear flood lights on and off. VEHICLE LIGHTS main switch section must be in SER. DRIVE position for these switches to operate.

BLACK OUT DRIVING LIGHTS. Mounted at left side of roll over protective structure. Provides forward black out illumination during tactical operations. Controlled by VEHICLE LIGHTS switch.

GAGE LIGHTS. Internal lights illuminate meter face and pointer of FUEL and OIL PRESS gages. Bright, dim and off settings controlled by VEHICLE LIGHTS switch.

FRONT FLOOD LIGHTS. Four sealed-beam type lamps mounted on roll over protective structure and steel channel extension of instrument panel. Illuminate

area in front of vehicle for driving forward and material handling. Turned on and off with FRONT FLOOD switch.

REAR FLOOD LIGHTS. Two sealed-beam type lamps mounted on bottom of steel plates behind radiator grille. Illuminate area behind vehicle for backing up, connecting tow bar, or connecting towed load. Turned on and off with REAR FLOOD switch.

SERVICE STOP AND TAIL LIGHTS. Two light assemblies mounted on top of steel plates behind radiator grille. Assembly includes incandescent lamp and red plastic lens. Tail lights turned on and off with VEHICLE LIGHTS switch. Stop lights are normally off; turned on by depressing service brake pedal.

BLACK OUT STOP AND TAIL LIGHTS. Two light assemblies mounted in protective metal housings at rear of vehicle. Each assembly contains two incandescent lamps. Provides stop light and tail light illumination during tactical operations. Tail lights turned on and off with VEHICLE LIGHTS switch. Stop lights are normally off; turned on by depressing service brake pedal.

b. Horn and Back-Up Alarm.

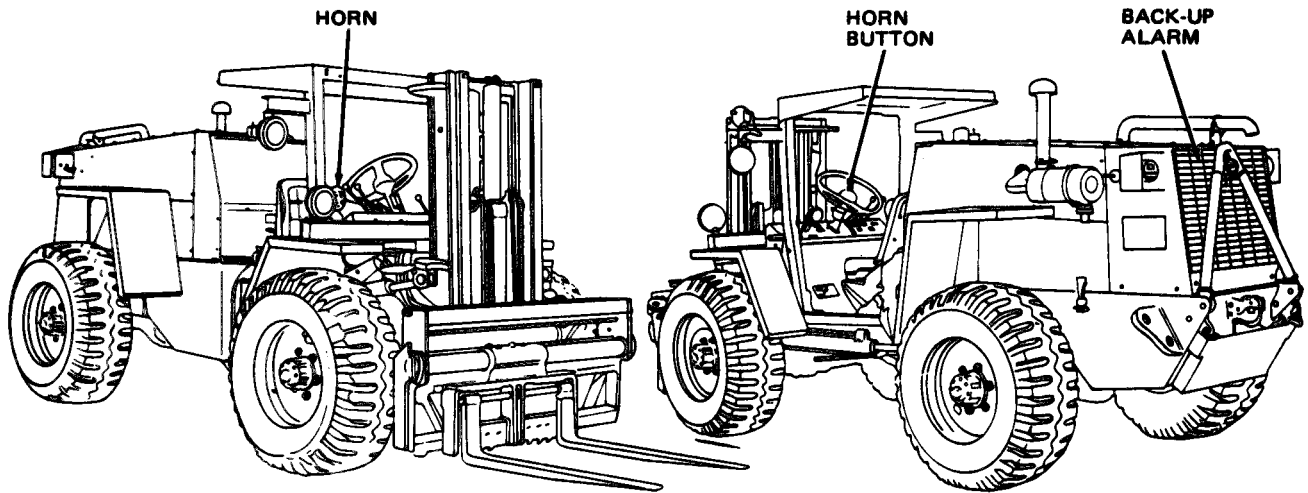

TA126786

HORN. Electrically operated by depressing horn button located on steering wheel. Located next to front flood light, on right side extension of instrument panel.

HORN BUTTON. Spring loaded button located at center of steering wheel. Horn sounds when button is depressed, and turns off when button is released. Horn and horn button operate at any position of the ignition switch, including OFF.

BACK-UP ALARM. Electrically operated alarm module located at rear of vehicle behind radiator grille. Sounds distinctive warning whenever transmission direction selector is in reverse (R) position. Ignition switch must be turned to ON position before back-up alarm will sound.

c. Switches and Warning Indicators.

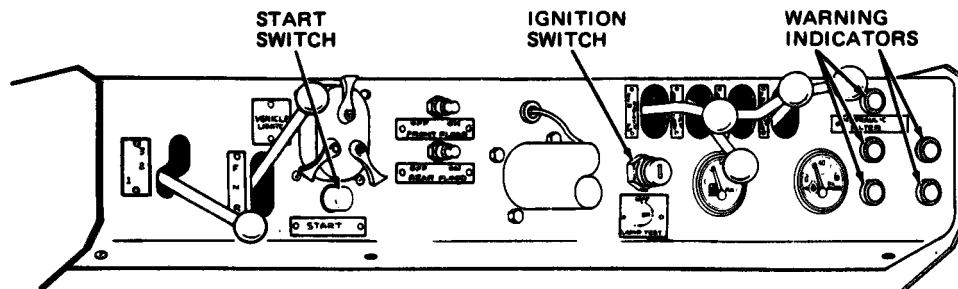

TA126787

IGNITION SWITCH. Four position key switch controls power to all vehicle electrical circuits except horn.

START SWITCH. Spring loaded pushbutton switch. When depressed, starter motor cranks to start engine. Ignition switch must be in ON position before START switch will crank starter motor.

WARNING INDICATORS. Five light assemblies; each contains incandescent lamp and red lens. With engine running, warning indicator illuminates to indicate malfunction (see chapter 2).

1-12. TRANSMISSION CONTROLS

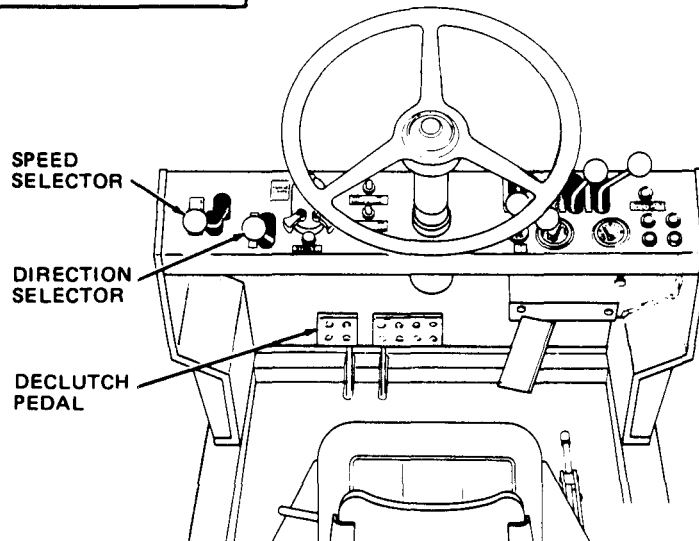

TA501744

SPEED SELECTOR. Selects one of three drive speed ranges for forward or reverse travel. Rearmost position provides greatest pulling power and lowest top speed; full forward position provides highest top speed.

DIRECTION SELECTOR. Three position lever control selects forward, neutral or reverse direction of travel. Reverse position also sounds back-up alarm module.

DECLUTCH PEDAL. Depressing pedal with foot applies service brake and shifts transmission to neutral range (regardless of position of direction selector). Releasing spring loaded pedal releases service brake and returns transmission to range (F, N, or R) selected by direction selector control.

1-13. BRAKE SYSTEM

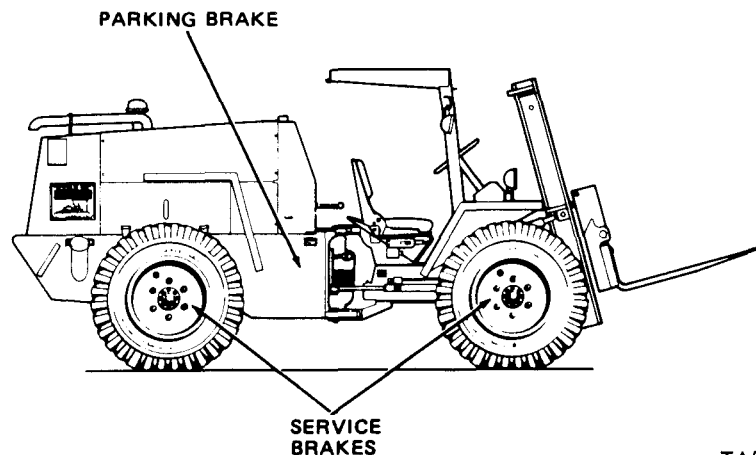
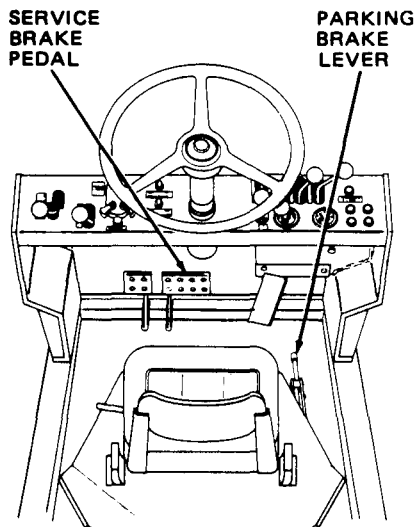

TA501745

SERVICE BRAKE PEDAL. Depressing pedal applies shoe and drum hydraulic brakes located at each wheel. Also illuminates service or blackout stop lights, as determined by position of VEHICLE LIGHTS switch. Releasing spring loaded pedal releases service brakes. Brake system is power assisted for reduced brake pedal effort when engine is running.

PARKING BRAKE LEVER. Located at right side of operator's seat. Pulling lever up applies drum-type parking brake located at output shaft of transmission, which prevents axles and wheels from rotating. Pushing lever down releases parking brake.

1-14. STEERING SYSTEM

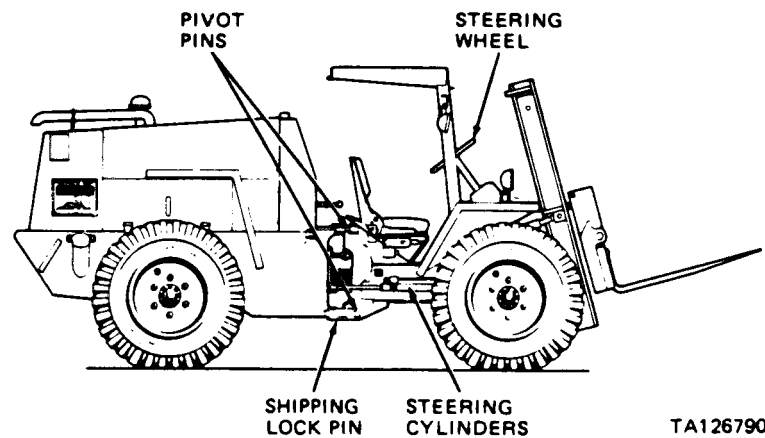

TA126790

PIVOT PINS. Heavy duty steel pins mounted in bushings, and located at top and bottom chassis connection points. Secure front chassis to rear chassis and allow front chassis to pivot and steer vehicle.

STEERING CYLINDERS. Two hydraulic cylinders, one mounted on each side of vehicle. Cylinder housings attached to front chassis, and cylinder rods attached to rear chassis. Cylinder rods extend or retract as steering wheel is turned, forcing front chassis to pivot about pivot pins and turn vehicle.

STEERING WHEEL. Connected to steering column and steering gear, which controls flow of hydraulic oil to and from steering cylinders. Power assist provided by hydraulic pump mounted on transmission for reduced steering wheel turning effort when engine is running.

SHIPPING LOCK PIN. Heavy duty steel pin, normally stored under operator's seat. Installs in mating holes in front and rear chassis to prevent articulation when shipping or jacking vehicles. Shipping lock pin must be removed to allow normal steering. Do not install the shipping lock pin when towing the vehicle.

1-15. BODY, TOWING ATTACHMENTS, AND TOWING CONTROLS

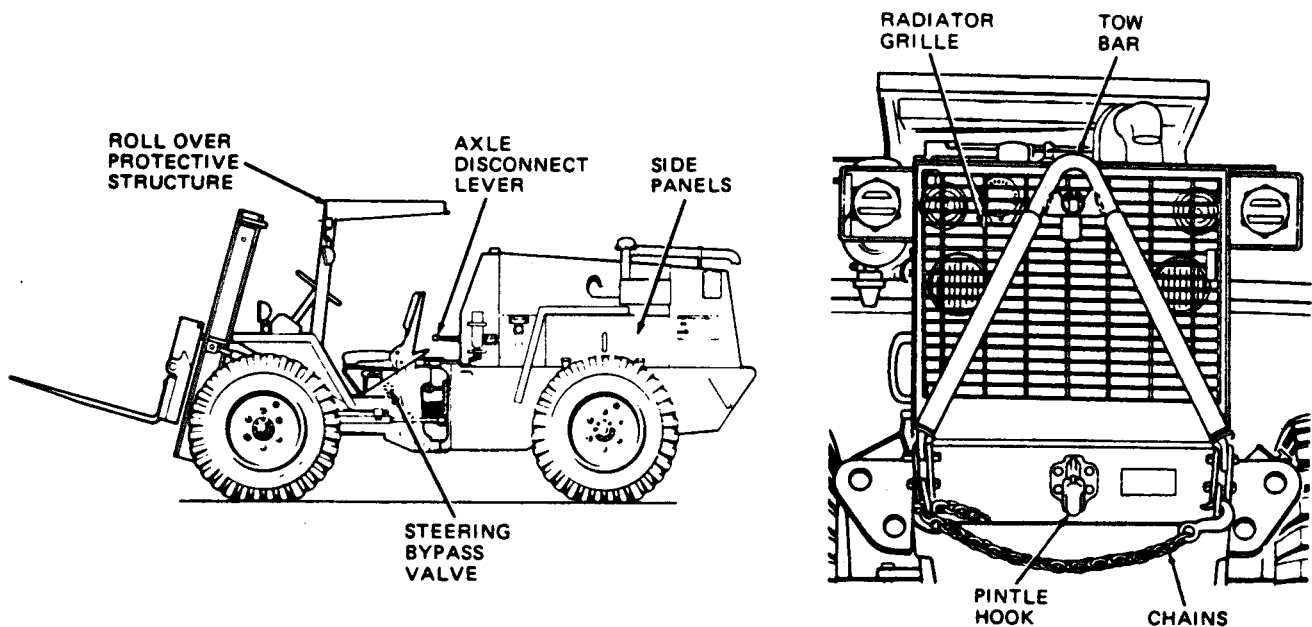

1-15. BODY, TOWING ATTACHMENTS, AND TOWING CONTROLS (cont)

ROLL OVER PROTECTIVE STRUCTURE. Constructed of heavy duty steel; bolted to front chassis. Protects operator from injury due to falling material and truck rolling over.

SIDE PANELS. Constructed of sheet metal; secured to rear chassis with latches. Provide access to engine compartment.

RADIATOR GRILLE. Welded steel construction; protects engine radiator, transmission oil cooler, and vehicle lights from damage. Swings open for access to batteries and radiator overflow bottle.

WARNING

The tow bar is provided to tow the forklift ONLY.

TOW BAR. Constructed of heavy duty steel; normally stowed in vertical position with retaining pin. Pivots to horizontal position to connect forklift truck to towing vehicle.

1-16. MAST ASSEMBLY

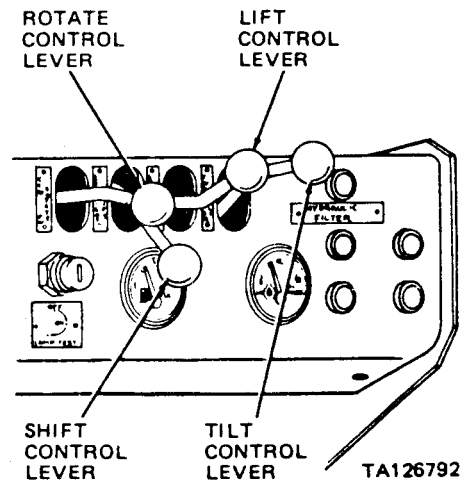
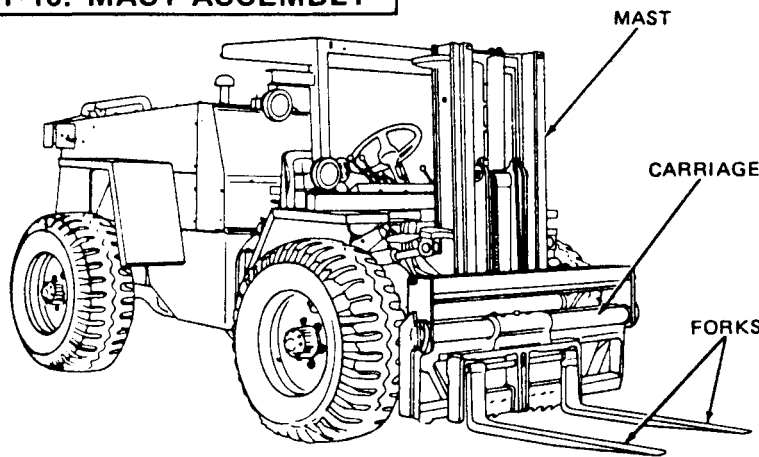

PINTLE HOOK. Manually operated latch type rigid pintle. Opened by removing cotter pin, pulling latch handle rearward, and lifting top jaw. Accepts standard 3 inch by 1-5/8 inch lunette for connecting towed load to forklift truck.

CHAINS. Steel link construction with attachment hooks; provide additional connection (safety) between forklift truck and towed load or towing vehicle.

STEERING BYPASS VALVE. Mounted on left side of operator's seat; turning valve handle counterclockwise disables steering system and allows front chassis to pivot freely about rear chassis and steering cylinders. Valve must be open when towing forklift truck, and must be closed (turned fully clockwise) for normal steering and truck operation.

AXLE DISCONNECT LEVER. Used to disengage axles from transmission when towing forklift truck to new location. Pulling lever outward allows transmission output shaft to freewheel, and prevent transmission damage or wear while towing. Lever must be pushed inward for normal truck operation.

MAST. Raises and lowers carriage. Hydraulic lift cylinder, controlled by LIFT control lever, raises and lowers two lift chains attached to carriage. Two hydraulic tilt cylinders, activated by TILT control lever, tilt mast forward or rearward.

FORKS. Constructed of heavy duty steel; mounted on carriage. Locking notches on carriage and locking lugs on forks permit adjustment of width between forks.

CARRIAGE. Rotates and side shifts forks. Hydraulic rotation cylinder controlled by ROTATE control lever; hydraulic side shift cylinder controlled by SHIFT control lever.

ROTATE CONTROL LEVER. Hold in forward position to rotate forks counterclockwise; hold in rearmost position to rotate forks clockwise.

LIFT CONTROL LEVER. Hold in forward position to lower carriage and forks; hold in rearmost position to raise carriage and forks.

SHIFT CONTROL LEVER. Hold in forward position to shift forks to left; hold in rearmost position to side shift forks to right.

TILT CONTROL LEVER. Hold in forward position to tilt mast and forks forward; hold in rearmost position to tilt mast and forks rearward.

CHAPTER 2 OPERATING INSTRUCTIONS

CHAPTER OVERVIEW
The purpose of this chapter is to familiarize you with the equipment so that you can operate it safely, efficiently and effectively.

Index

Section	Title	Page
I	Description and Use of Operator's Controls and Indicators.	2-1
II	Preventive Maintenance Checks and Services (PMCS)	2-9
III	Operation Under Usual Conditions	2-13
IV	Operation Under Unusual Conditions	2-21

Section I. DESCRIPTION AND USE

OPERATOR'S CONTROLS AND INDICATORS

	Para		Para
Instrument Panel	2-1	Externally Mounted Controls	
Brake and Throttle Controls	2-2	and Indicators	2-4
Operator's Compartment	2-3	Other Operator's Controls and Indicators	2-5

2-1. INSTRUMENT PANEL

a. *Gages.*

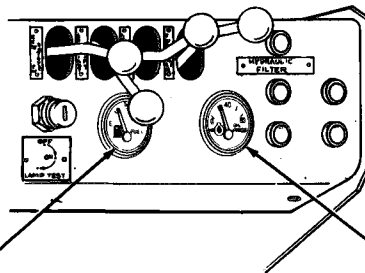

FUEL GAGE

Indicates quantity of fuel remaining in fuel tank.

Calibrated in six gallon increments. Fuel tank holds approximately 27 gallons of fuel; therefore, when gage indicates half full, approximately 13 gallons of fuel remains.

OIL PRESS GAGE

Indicates engine oil pressure.

Calibrated in 20 PSI increments to a maximum of 80 PSI. Normal oil pressure is 50 to 70 PSI. If pressure indication is below 50 PSI or above 70 PSI and if OIL PRESSURE indicator is lit, turn engine off and check cause. If OIL PRESSURE indicator is not lit, continue operation and report oil pressure gage abnormal indication to organizational maintenance.

TA126793

2-1. INSTRUMENT PANEL (cont)

b. Indicators.

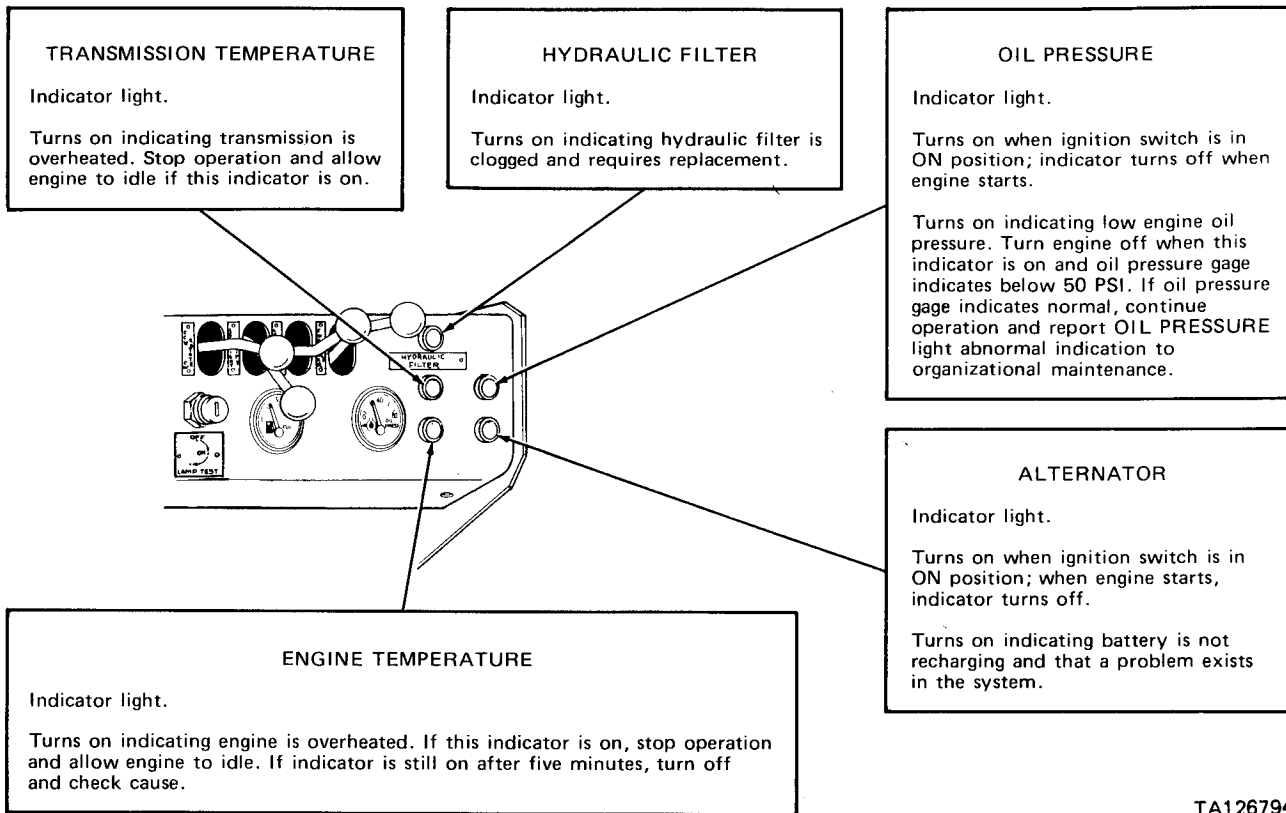

TA126794

2-1. INSTRUMENT PANEL (cont)

c. VEHICLE LIGHTS Switch.

AUXILIARY SWITCH

Four position switch section.

PANEL BRT.: Engine OIL PRESS gage and FUEL gage lamps brightly lit.

DIM: Engine OIL PRESS gage and FUEL gage lamps dimly lit.

OFF (unmarked): Panel and tail lamps off.

PARK: Service tail lamps lit (main switch in SER DRIVE position) and gage lights dimly lit. Black out tail lamps lit (main switch in B. O. DRIVE or B. O. MARKER position).

NOTE

Main switch section must be in any position other than OFF for auxiliary switch section to operate.

MAIN SWITCH

Five position switch section.

B. O. MARKER: Black out tail lamps lit and stop light switch enabled (black out stop lamp will light when brakes are applied).

B. O. DRIVE: Black out tail lamps and black out driving lamp lit, and stop light switch enabled (black out stop lamp will light when brakes are applied). Mechanical lock lever must be held in UNLOCK to move main switch lever to this position.

OFF (unmarked): All lamps off and auxiliary and stop light switch disabled.

STOP LIGHT: Stop light switch enabled (service stop lamp will light when brakes are applied). Mechanical lock lever must be held in UNLOCK to move main switch lever to this position.

SER DRIVE: Service tail lamp lit, stop light switch enabled (service stop lamp will light when brakes are applied), and front flood lights and rear flood lights switches are enabled. Mechanical lock lever must be held in UNLOCK to move main switch lever to this position.

NOTE

Ignition switch must be in extreme left or ON position for VEHICLE LIGHTS switch to operate.

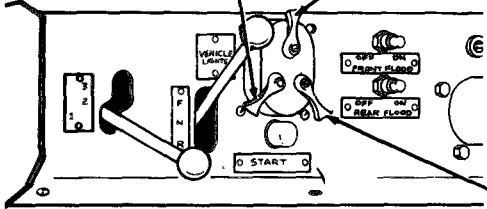

MECHANICAL LOCK

Spring loaded switch section.

LOCK (unmarked): Main switch can only be placed in B. O. MARKER position; all other positions locked out..

UNLOCKED: Enables main switch to be placed in B. O. DRIVE, STOP LIGHT, or SER DRIVE position.

To operate, hold lever in UNLOCK position and move main switch lever to desired position.

TA126795

2-1. INSTRUMENT PANEL (cont)

d. Flood Lights and Engine Switches.

FRONT FLOOD SWITCH

Two position toggle switch.

ON: Turns on front flood lights

NOTE

Main switch on VEHICLE LIGHTS switch must be in SER. DRIVE position for this switch to operate.

OFF: Turns off front flood lights.

REAR FLOOD SWITCH

Two position toggle switch.

ON: Turns on rear flood lights.

NOTE

Main switch on VEHICLE LIGHTS switch must be in SER. DRIVE position for this switch to operate.

OFF: Turns off rear flood lights.

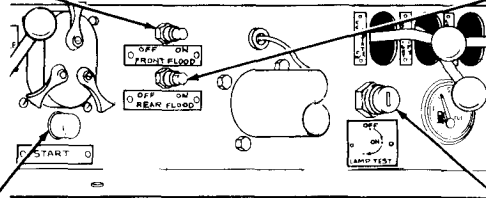

START SWITCH

Pushbutton switch.

Depressed: With ignition switch in ON position, cranks starting motor to start engine.

IGNITION SWITCH

Four position key switch.

Unmarked position (key turned counterclockwise): Applies power to VEHICLE LIGHTS switch enabling lights to be turned on.

OFF (key straight): Ignition and lighting system off.

ON (key turned to first clockwise position): Applies power to VEHICLE LIGHTS switch, engine OIL PRESS and FUEL gages, indicator lights, fuel pump, fuel injection pump solenoid, back-up alarm switch and START switch.

LAMP TEST (extreme clockwise position, spring loaded return): Tests operation of HYDRAULIC FILTER, transmission temperature, and engine temperature indicators; these three indicators will turn on in this switch position.

TA126796

2-1. INSTRUMENT PANEL (cont)

e. Transmission Control Levers.

SPEED SELECTOR
 Selects drive speeds in either forward or reverse.
 Rearmost position is first (1) speed, next position is second (2) speed, and front position is third (3) speed.
 Lever can be in any position when starting engine.

DIRECTION SELECTOR
 Selects direction of travel.
 Rearmost position is reverse (R), next position is neutral (N), and front position is forward (F). When direction selector is placed in reverse, back-up alarm located at rear of vehicle will sound.
 Lever must be in neutral to start engine.

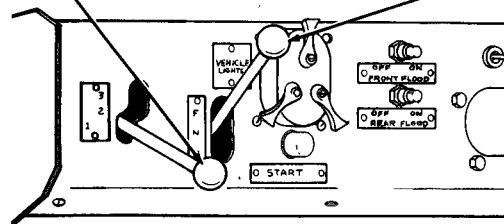

TA126797

f. Fork Lift Control Levers.

ROTATE CONTROL LEVER
 Rotates forks.
 CCW (forward) position: rotates forks counter-clockwise.
 CW (rear) position: rotates forks clockwise.

LIFT CONTROL LEVER
 Raises/lowers forks.
 LOWER (forward) position: lowers forks.
 RAISE (rear) position: raises forks.

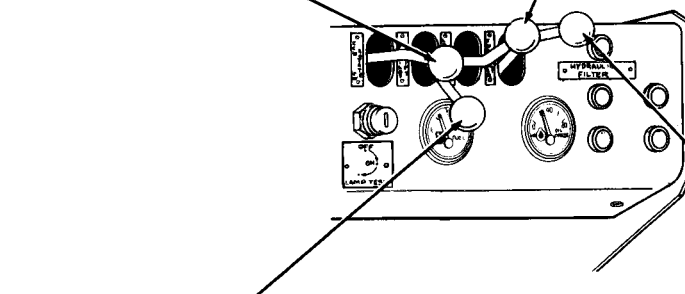

SHIFT CONTROL LEVER
 Shifts forks right or left.
 LEFT (forward) position: shifts forks to left.
 RIGHT (rear) position: shifts forks to right.

TILT CONTROL LEVER
 Tilts mast forward or rearward.
 FWD (forward) position: tilts mast forward.
 REAR position: tilts mast rearward.

TA126798

2-2. BRAKE AND THROTTLE CONTROLS

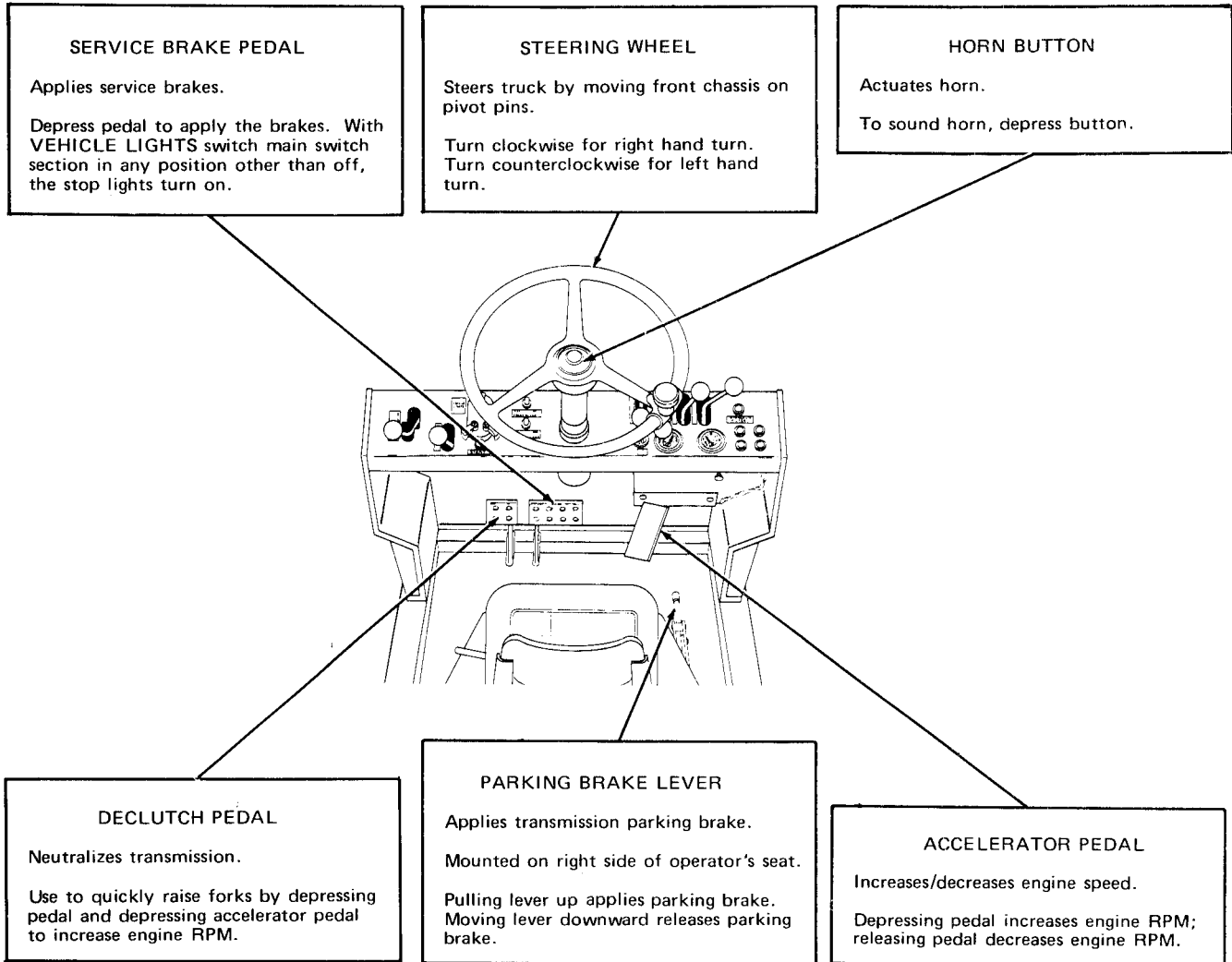

TA126799

2-3. OPERATOR'S COMPARTMENT

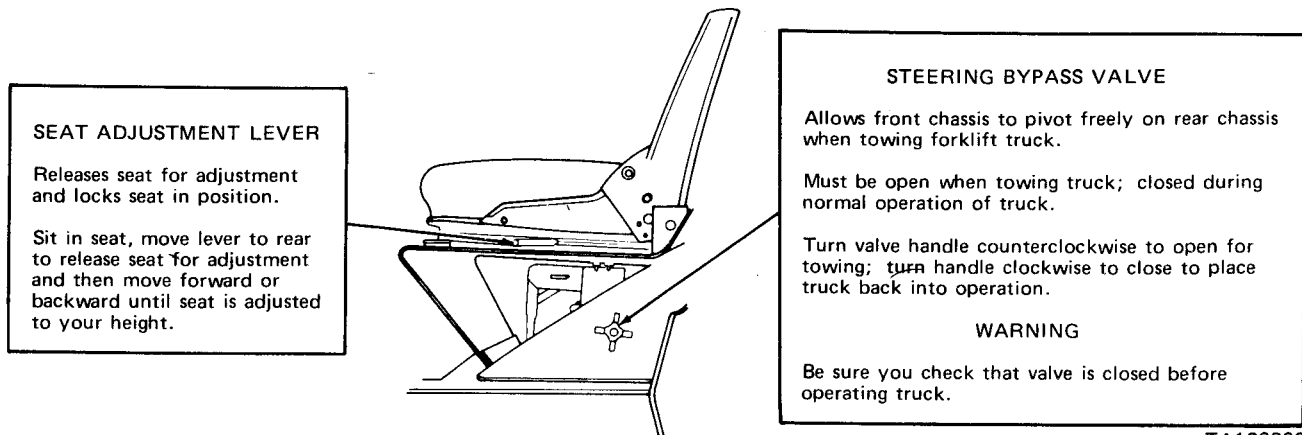

TA126800

2-4. EXTERNALLY MOUNTED CONTROLS AND INDICATORS

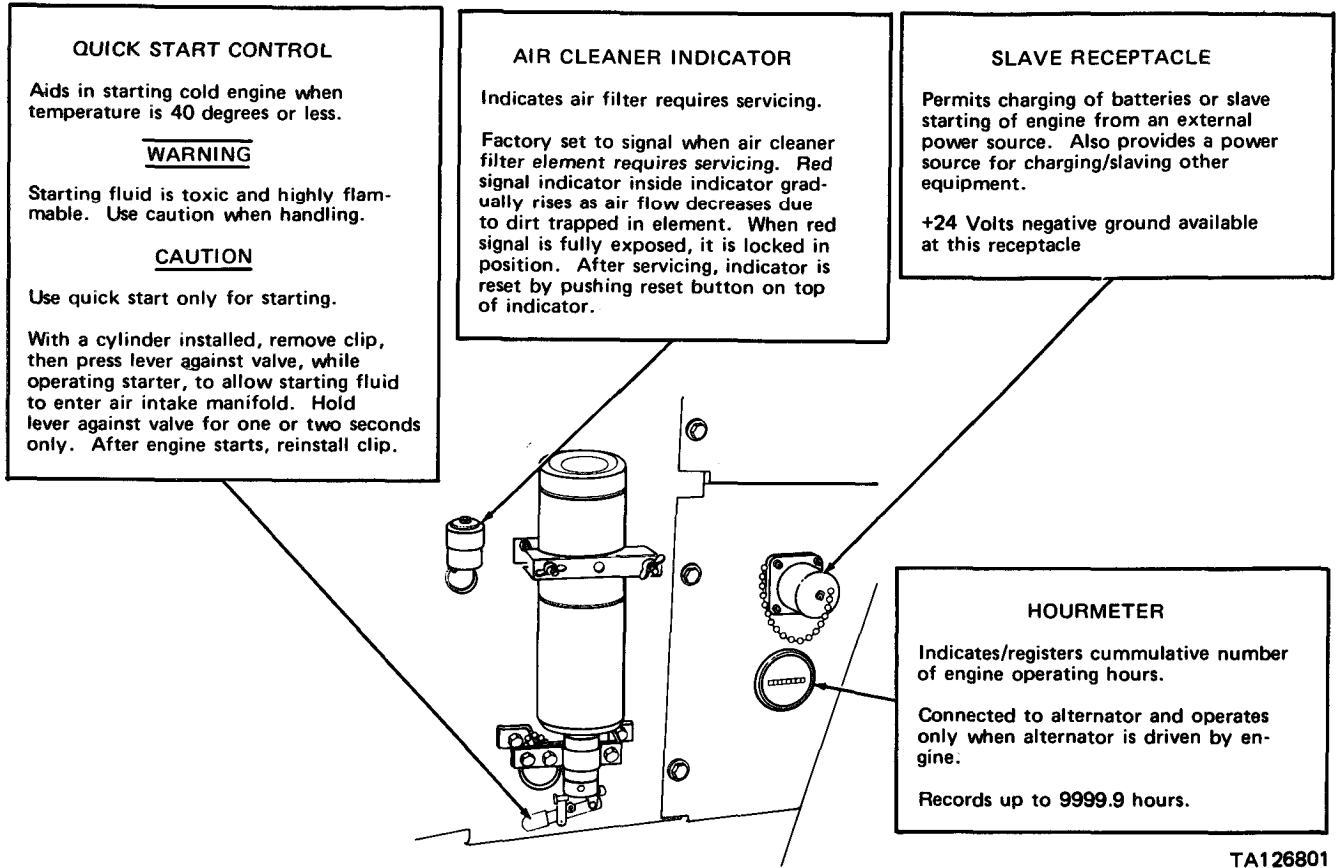

2-5. OTHER OPERATOR'S CONTROLS AND INDICATORS

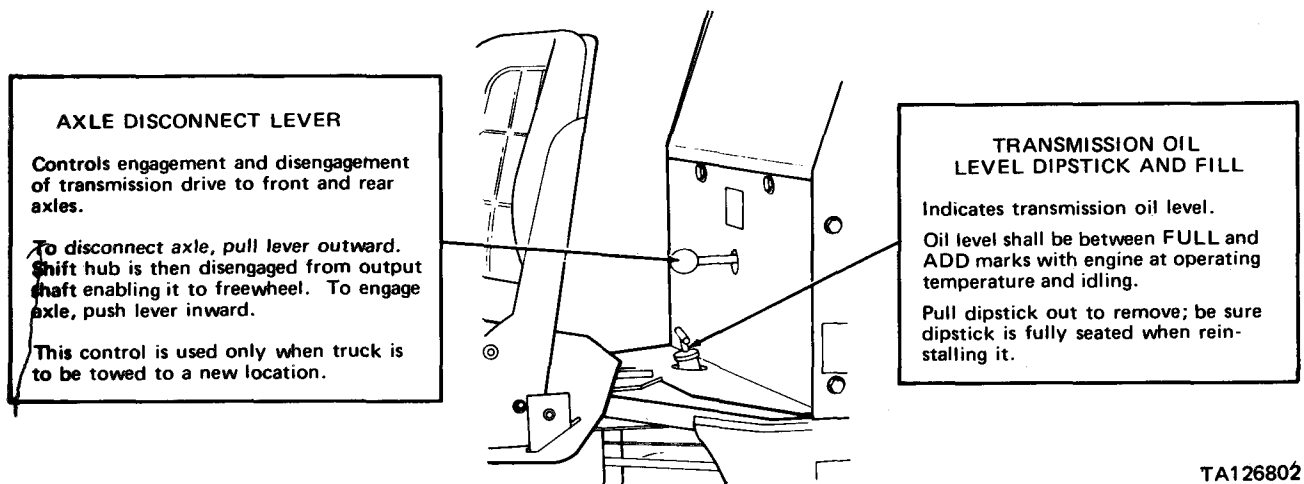

2-5. OTHER OPERATOR'S CONTROLS AND INDICATORS (cont)

ENGINE OIL LEVEL DIPSTICK AND FILL
Indicates engine oil level.
Oil level shall be between FULL and ADD marks with engine off.
Pull dipstick out to remove; be sure dipstick is fully seated when re-installing it.

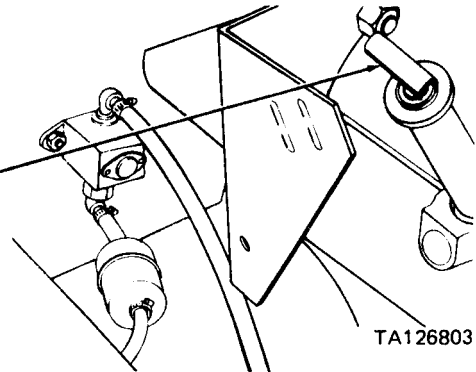

TA126803

HYDRAULIC SYSTEM OIL LEVEL DIPSTICK AND FILL
Indicates hydraulic system hydraulic oil level.
Oil level shall be between FULL and ADD marks with mast lowered.
Pull dipstick out to remove; be sure dipstick is fully seated when reinstalling it.

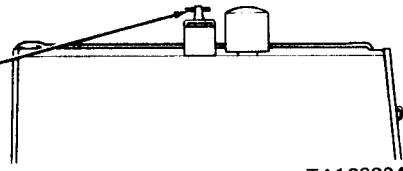

TA126804

Section II. PREVENTIVE MAINTENANCE CHECKS AND SERVICES (PMCS)

2-6. MAINTENANCE FORMS AND RECORDS

Every mission begins and ends with the paperwork. There isn't much of it, but you have to keep it up. The forms and records you fill out have several uses. They are a permanent record of the services, repairs and modifications made on your vehicle. They are reports to organizational maintenance and to your Commander. And they are a checklist for you when you want to know what is wrong with the vehicle after its last use, and whether those faults have been fixed. For the information you need on forms and records, see DA Pam 738-750.

2-7. PREVENTIVE MAINTENANCE CHECKS AND SERVICES

a. Do your before(B) PREVENTIVE MAINTENANCE just before you operate the vehicle. Pay attention to the CAUTIONS and WARNINGS.

b. DURING checks and services(D) of PREVENTIVE MAINTENANCE will be performed while the equipment and/or its component systems are in operation.

c. Do your after (A) PREVENTIVE MAINTENANCE right after operating the vehicle. Pay attention to the CAUTIONS and WARNINGS.

d. Do your weekly (W) PREVENTIVE MAINTENANCE weekly.

e. Do your monthly (M) PREVENTIVE MAINTENANCE once a month.

f. If something doesn't work, troubleshoot it with the instructions in this manual or notify your supervisor.

g. Always do your PREVENTIVE MAINTENANCE in the same order so it gets to be a habit. Once you've had some practice, you'll spot anything wrong in a hurry.

h. If anything looks wrong and you can't fix it, write it on your DA Form 2404. If you find something seriously wrong, report it to organizational maintenance RIGHT NOW.

i. When you do your PREVENTIVE MAINTENANCE, take along the tools you need to make all the checks. You always need a rag or two.

WARNING

Dry cleaning solvent, used to clean parts is potentially dangerous to personnel and property. Do not use near open flame or excessive heat. Flash point of solvent is 138 degrees F.

(1) Keep it clean: Dirt, grease, oil and debris only get in the way and may cover up a serious problem.

Clean as you work and as needed. Use dry cleaning solvent (P-D-680) on all metal surfaces. Use soap and water when you clean rubber or plastic material.

(2) Bolts, nuts and screws: Check them all for obvious looseness, missing, bent or broken condition. You can't try them all with a tool, of course, but look for chipped paint, bare metal or rust around bolt heads. If you find one you think is loose, tighten it, or report it to organizational maintenance if you can't tighten it.

(3) Welds: Look for loose or chipped paint, rust or gaps where parts are welded together. If you find a bad weld, report it to organizational maintenance.

(4) Electric wires and connectors: Look for cracked or broken insulation, bare wires and loose or broken connectors. Tighten loose connectors and make sure the wires are in good shape.

(5) Hoses and fluid lines: Look for wear, damage and leaks, and make sure clamps and fittings are tight. Wet spots show leaks, of course, but a stain around a fitting or connector can mean a leak. If a leak comes from a loose fitting or connector, tighten it. If something is broken or worn out, report it to organizational maintenance.

j. It is necessary for you to know how fluid leakage affects the status of your vehicle. The following are definitions of the types/classes of leakage you need to know to be able to determine the status of your vehicle. Learn, then be familiar with them and REMEMBER-WHEN IN DOUBT, NOTIFY YOUR SUPERVISOR!

Leakage Definitions for Crew/Operator PMCS

Class I Seepage of fluid (as indicated by wetness or discoloration) not great enough to form drops.

Class II Leakage of fluid great enough to form drops but not enough to cause drops to drip from item being checked/inspected.

Class III Leakage of fluid great enough to form drops that fall from the item being checked, inspected.

CAUTION

EQUIPMENT OPERATION IS ALLOWABLE WITH MINOR LEAKAGES (CLASS I OR II). OF COURSE, CONSIDERATION MUST BE GIVEN TO THE FLUID CAPACITY IN THE ITEM/SYSTEM BEING CHECKED/INSPECTED. WHEN IN DOUBT, NOTIFY YOUR SUPERVISOR.

CLASS III LEAKS SHOULD BE CORRECTED IMMEDIATELY OR REPORTED TO YOUR SUPERVISOR OR ORGANIZATIONAL MAINTENANCE.

Table 2-1. Operator PMCS

B — Before D — During A — After W — Weekly M — Monthly

Item No.	Interval					ITEM TO BE INSPECTED Procedure: Check For And Have Repaired, Filled Or Adjusted As Needed	Equipment is Not Ready/ Available If:
	B	D	A	W	M		
1	•					<p>IMPORTANT: PERFORM WEEKLY AS WELL AS BEFORE OPERATIONS PMCS IF:</p> <p>1. YOU ARE THE ASSIGNED OPERATOR AND HAVE NOT OPERATED THE VEHICLE SINCE THE LAST WEEKLY.</p> <p>2. YOU ARE OPERATING THE VEHICLE FOR THE FIRST TIME.</p> <p>NOTE</p> <p>Have the following three operations performed by Organizational and Direct Support Maintenance at 20 hours to comply with warranty also if engine is rebuilt or cylinder head is removed.</p> <p>1. Replace engine oil and filter.</p> <p>2. Torque cylinder head bolts.</p> <p>3. Adjust valve tappet clearance.</p> <p>EXTERIOR OF VEHICLE</p> <p>a. Check for leaks or appearance of leaks.</p> <p>b. Visually check Roll Over Protective Structure (ROPS) and Falling Object Protection Structure (Fops) for obvious damage.</p> <p>c. Visually check forks, carriage, side shifter frame for cracked, bent, or broken frame members.</p> <p>d. Check lift and side shift chains for 1/2 inch deflection by depressing chain in center.</p> <p>e. Visually check wiring harness and connections for frayed or broken wires.</p> <p>f. Check towbar for any bends, cracks or cracked welds.</p> <p>STEERING BYPASS VALVE</p> <p>Check that steering bypass valve is closed (fully-clockwise) and that shipping lockpin is removed.</p> <p>ENGINE OIL LEVEL</p> <p>Check level on dipstick and add oil as required to bring level up to full mark.</p>	<p>Class III leaks.</p> <p>ROPS is bent, cracked or damaged or missing hardware.</p> <p>Forks, carriage, side shifter frame are cracked bent, or broken.</p> <p>Broken or missing chains.</p> <p>Towbar is bent, cracked, or damaged in any way.</p>
2	•						
3	•						

Table 2-1. Operator PMCS (cont)

Item No.	Interval					ITEM TO BE INSPECTED Procedure: Check For And Have Repaired, Filled Or Adjusted As Needed	Equipment is Not Ready/ Available If:
	B	D	A	W	M		
						<p>PRIMARY FUEL FILTERS</p>  <p>TA501746</p>	
4	•					<p>a. Drain water from primary fuel filters.</p> <p>b. In freezing weather, drain water from filters after operating.</p>	
5	•					<p>RADIATOR RECOVERY RESERVOIR</p> <p>Check to ensure coolant is at cold mark level, add as required.</p>	
6	•					<p>TIRES AND WHEELS</p> <p>Check tires for wear, nails and foreign objects, missing or loose lug nuts (240-260 lb. ft. torque), and correct pressure (45 psi).</p>	Tire with less than 1/4 inch tread or abrasions which would result in tire failure during operation.
7	•					<p>HYDRAULIC RESERVOIR</p> <p>With mast lowered, check reservoir oil level. If necessary, add oil to bring up level to full mark on dipstick.</p>	
8	•					<p>FIRE EXTINGUISHER</p> <p>Check availability of extinguisher (if authorized locally) and proper pressure (indicator in green).</p>	
9		•				<p>SEAT BELT</p> <p>Check that belt is securely mounted, material is not frayed, and latch is operable.</p>	Belt not securely mounted, material is frayed, and latch is inoperable.

Table 2-1. Operator PMCS (cont)

Item No.	Interval					ITEM TO BE INSPECTED Procedure: Check For And Have Repaired, Filled Or Adjusted As Needed	Equipment is Not Ready/ Available If:
	B	D	A	W	M		
10		•				LIGHTS AND HORN Check that head, tail, flood, blackout lights and horn are working.	
11		•				INDICATOR LIGHTS, OIL PRESSURE GAUGE, AND HOURMETER Check that alternator and oil pressure warning lamps are not lit. Check oil pressure gauge for normal reading of 50-70 psi, and hourmeter is working.	Alternator lamp or oil pressure lamp are lit. Oil pressure gauge not within normal range.
12		•				LAMP TEST With engine running, check that hydraulic filter by-pass, transmission temperature, and engine temperature indicator lights function in test phase. NOTE If HYDRAULIC FILTER light comes on during operation, finish shift and have filter replaced before further operation.	Engine or transmission lamp does not function or engine temperature or transmission temperature indicator lamp comes on during operation,
13		•				LIFT FORK CONTROLS Check that lift, tilt, side shift, and rotation movement is smooth and immediate.	Any function fails to operate or is erratic.
14		•				STEERING Check that truck steers freely and easily.	Steering sticks, binds, or is hard to steer.
15		•				PARKING BRAKE Check that brake holds vehicle. Turn knob clockwise to tighten.	
16		•				ACCELERATOR Check that accelerator operates smoothly.	Pedal sticks.
17		•				TRANSMISSION CONTROLS Check that transmission shift levers operate smoothly and correct gear and range are engaged.	Transmission does not operate.
18		•				BACK-UP ALARM Check that alarm sounds in reverse.	
19		•				BRAKES Check that normal brake pressure stops truck.	Service brake won't stop truck.

Table 2-1. Operator PMCS (cont)

B - Before D - During A - After W - Weekly M - Monthly

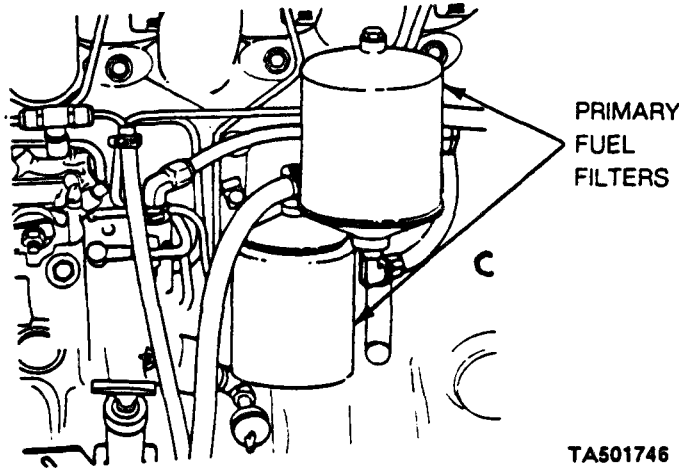
Item No.	Interval					ITEM TO BE INSPECTED Procedure: Check For And Have Repaired, Filled Or Adjusted As Needed	Equipment is Not Ready/ Available If
	B	D	A	W	M		
20		•				TRANSMISSION FLUID At operating temperature, engine idling check level on dipstick and add fluid as required to bring up level to full mark on dipstick.	
21		•				AIR CLEANER Check contamination indicator. Have serviced if indicator shows red.	
22				•		FAN AND DRIVE BELT a. Check belt for frayed or damaged condition. b. Check fan for bent or damaged blades.	
23				•		BATTERIES Inspect for electrolyte level, add distilled water if available or clean water. In freezing weather, run engine 15 minutes after adding water (reference TM 9-6140-200-14). Check that cables are clean.	Battery cracked or missing.

Section III. OPERATION UNDER USUAL CONDITIONS

Initial Checks	Para 2-8
Operating Procedures	2-9
Preparation for Movement	2-10

Operating Instructions on Decals and Instruction Plates	Para 2-11
---	-----------

2-8. INITIAL CHECKS

Refer to current Lubrication Order and lubricate fork-lift truck. Refer to paragraph 2-7 and perform before operation PMCS.

2-9. OPERATING PROCEDURES

a. Starting the Engine.

WARNING

Noise level exceeds 85 dB(A) at three feet in front, 15 feet at side and 24 feet at rear of vehicle. All personnel shall wear a hearing protection device when operating the vehicle.

WARNING

Before starting engine, check and be sure that STEERING BYPASS valve is closed (fully clockwise) and that shipping lock pin has been removed. Failure to do so will cause loss of steering control which may result in serious injury or death and damage to equipment.

- (1) Remove shipping lock pin by slipping ring of klik pin down from body of shipping lock pin then removing klik pin. Remove shipping lock pin from chassis, install klik pin and store shipping lock pin under operator's seat.

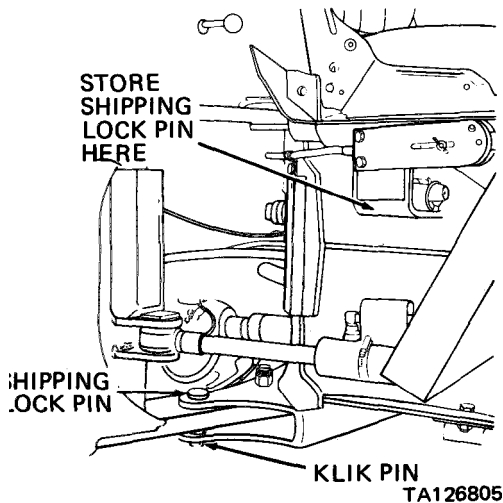

- (2) Mount truck and sit in operator's seat.
- (3) If necessary, adjust seat by moving lever to rear to release seat for adjustment and move seat forward or backward.
- (4) Fasten seat belt.

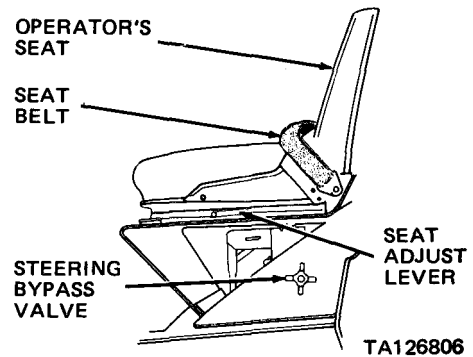

- (5) Pull parking brake lever towards you to act parking brake.

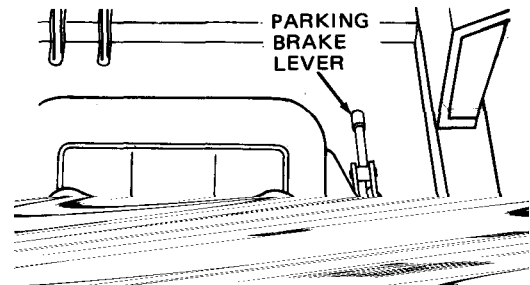

- (6) Place transmission DIRECTION SELECTOR in neutral (N) position.

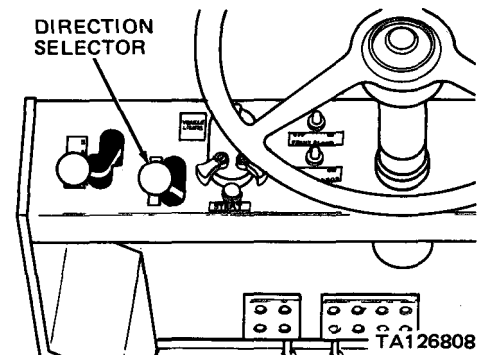

- (7) Insert key into ignition switch; turn key to first position clockwise (ON position).

a. Starting the Engine (cont).

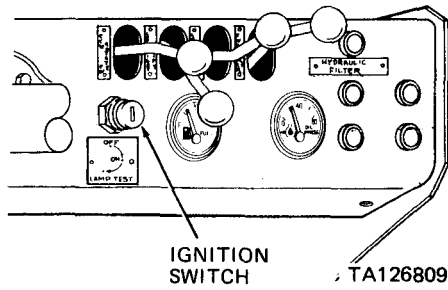

WARNING

Be sure your seat belt is fastened before starting engine.

- (8) Depress accelerator pedal 1/3 to 1/2 from normal position.

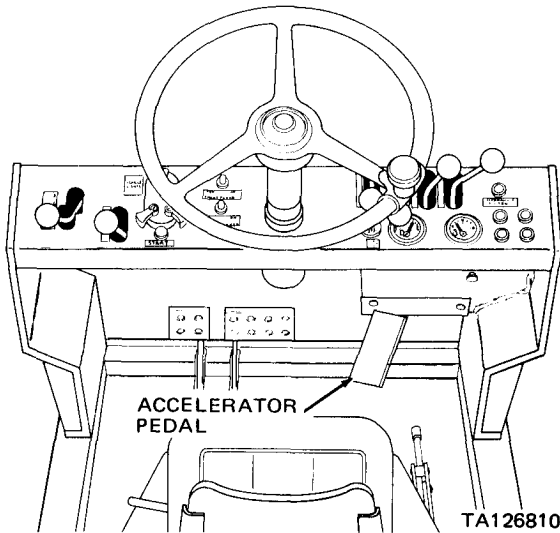

CAUTION

Don't operate starter motor for more than 30 seconds. Wait at least three minutes before cranking to allow batteries to recuperate and starter motor to cool.

- (9) Depress START pushbutton switch.

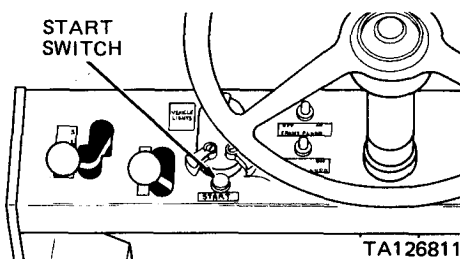

WARNING

Starting fluid is toxic and highly flammable, Container is pressurized to act as an expellent. Don't heat container and don't discharge starting fluid in confined areas or near open flame. Don't discard used container in an open flame.

- (10) If temperature is below 40 degrees F, use quick start aid. Remove clip, then engage starter while pressing quick start lever and hold lever for one or two seconds.

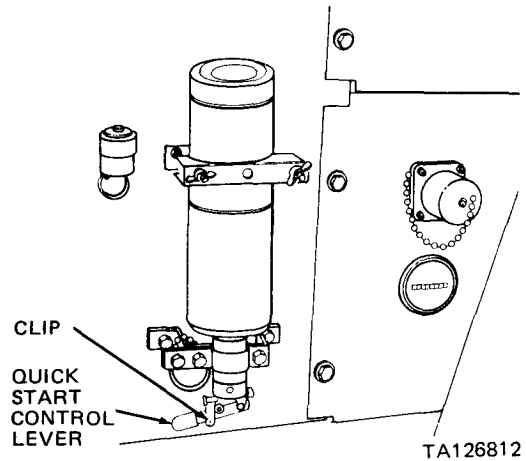

CAUTION

If there is no oil pressure indication on OIL PRESS gage within ten to 15 seconds and if oil pressure lamp is lit, turn engine off and check cause.

- (11) When engine starts, release START pushbutton switch immediately. Reinstall clip in quick start aid.
- (12) Ten to 15 seconds after engine starts, check OIL PRESS gage for proper indication. If proper indication is not obtained on gage, turn engine off and check cause if oil pressure lamp is lit.

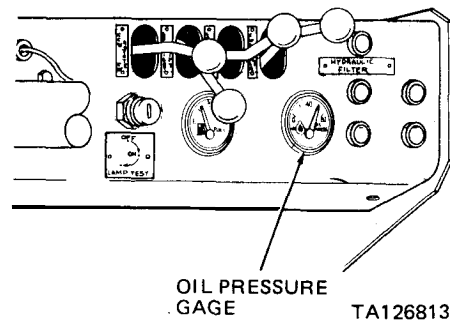

a. Starting the Engine (cont).

(13) Check control panel indicators for proper indication:

- (a) If oil pressure indicator is lit and if OIL PRESS gage indication is abnormal, turn engine off if OIL PRESS gage indication is normal, continue operation and report indicator abnormal indication to organizational maintenance.
- (b) If alternator indicator is lit, turn engine off and check cause.

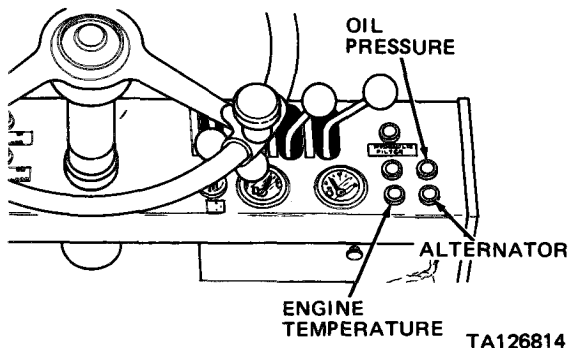

(14) Operate engine at 1/3 throttle and no load for five minutes allowing engine to warm before applying a load. If engine temperature indicator lights, stop operation and allow engine to idle. If indicator is still on after five minutes, turn engine off and check cause.

b. Starting the Forklift Truck.

(1) Operate LIFT control lever and raise forks no less than 12 inches from ground.

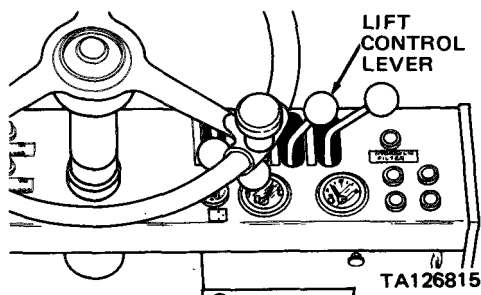

(2) Place main switch lever on VEHICLE LIGHTS switch in STOP LIGHT position.

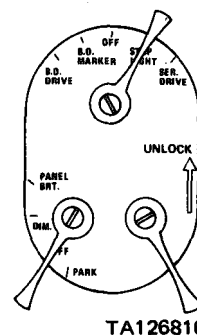

(3) Depress brake pedal.

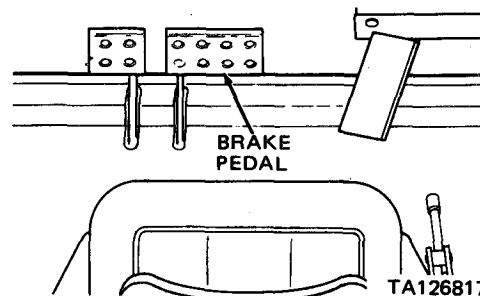

(4) Release parking brake lever.

NOTE

If vehicle doesn't move in following steps, push AXLE DISCONNECT lever inward.

- (5) Move transmission direction selector to desired position.
- (6) Move transmission speed selector to desired speed range.

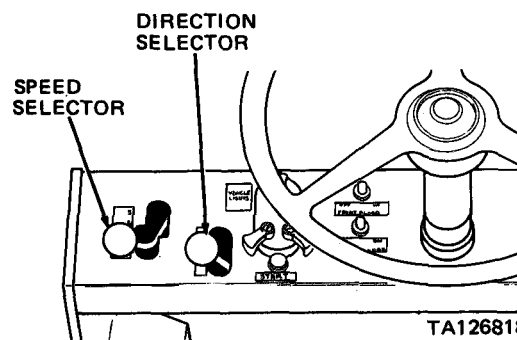

- (7) Release brake pedal and depress accelerator pedal as required to move forklift truck and accelerate to desired speed.
- (8) When shifting from neutral to any speed range, engine should beat idle speed. A shift to second or third speed forward from first speed forward can be made at full throttle, under load. Downshift to first or second speed may be made at full throttle, under load, providing the vehicle is not exceeding maximum speed attainable in lower speed.

b. Starting the Forklift Truck (cont).

- (9) Directional shifts can be made under full power and/ or full speed conditions in first speed forward to reverse or reverse to first speed forward. Shifts from reverse should be made to first speed forward not to second or third speed forward. Direct shifts from reverse to second or third speed will adversely affect clutch life.

NOTE

When operating on soft sand at slow speeds (not exceeding 10 MPH), tire inflation pressure may be decreased to 30 PSI for improved traction.

CAUTION

When operating in excess of 10 MPH or on hard surface terrain or roads, standard tire inflation pressure of 45 PSI should be maintained.

NOTE

When operating in high temperature conditions, additional cooling may be obtained by removing grille and towing bar (notify organizational maintenance).

- (10) The declutch pedal can be used during operation in any speed range. Use the declutch pedal to quickly raise the forks by depressing pedal and depressing accelerator pedal to increase engine RPM. Depressing the declutch pedal releases the driving clutch and applies the service brakes.

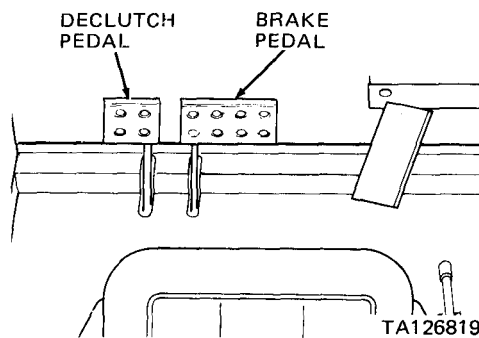

- (11) Check TRANS TEMP indicator on instrument panel. If indicator is flashing on and off or on steadily, place transmission direction selector in neutral and operate engine at

approximately 1000 to 1500 RPM until indicator is off. If indicator is still on steadily after five minutes, stop engine and check for cause.

- (12) If HYDRAULIC FILTER indicators illuminated, continue operation and notify organizational maintenance at end of work shift.

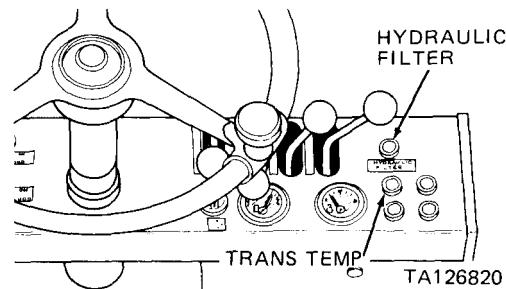

c. Stopping the Forklift Truck.

- (1) Depress brake pedal to stop forklift truck.
- (2) Place transmission direction selector in neutral (N) position.
- (3) Set parking brake by pulling parking brake lever towards you.
- (4) Lower forks to ground by operating LIFT control lever.
- (5) Before stopping engine, allow engine to run at idle speed with no load for four or five minutes.
- (6) Turn key in ignition switch to OFF position to shut off engine.

d. Operating the Forklift.

- (1) Adjusting Forks.
 - (a) Lift end of fork to disengage locking lug from notch in support,
 - (b) Slide fork to desired position and then lower fork until lug is engaged in desired notch,

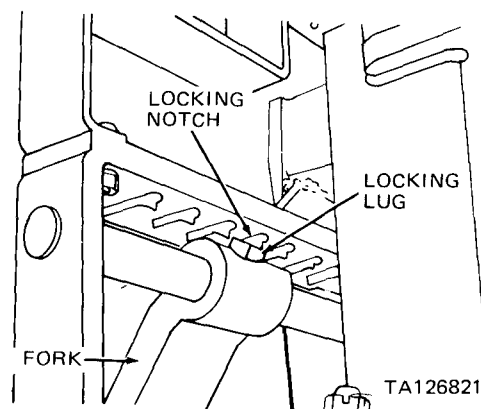

d. Operating the Forklift (cont).

(2) Picking Up the Load.

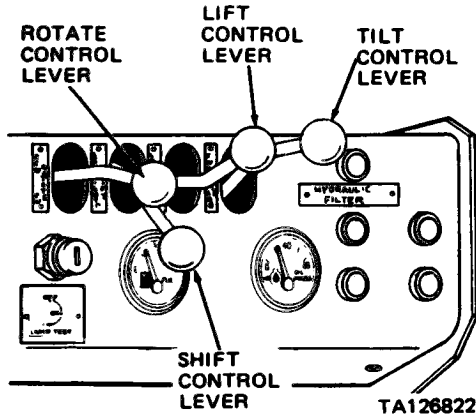

- (a) Operate TILT control lever to position mast in a vertical position.
- (b) Operate LIFT control lever to position forks at desired height.

NOTE

Control levers will return to neutral position automatically.

- (c) Center forklift truck on load and move truck forward slowly to move forks under load. Pull LIFT control lever towards you until load is raised to desired height.
 - (d) If angle of load is not same as that of truck when approaching load, use ROTATE control lever to level forks with load.
 - (e) If quarters are tight, use SHIFT control lever to center forks on load.
- (3) Tilting Load. Pull TILT control lever slowly towards you to tilt load towards truck. This will avoid possibility of load slipping forward off forks. When load reaches a safe degree of tilt, release TILT control lever.

WARNING

Always operate vehicle at a safe speed. Avoid overloading and sudden stops. Caution is advised when operating on a slope with any load. Do not tilt load out beyond vertical position of mast when elevated unless load is over a stack.

- (4) Transporting Load. With load raised a minimum of 12 inches from ground and tilted, operate forklift truck at a safe speed for type of load and terrain. Use ROTATE control lever to balance uneven loads and to level load when operating on slopes.

(5) Depositing Load.

- (a) Push TILT control lever away from you to move mast to a vertical position.
- (b) Move LIFT control lever away from you to lower load until load rests on ground.
- (c) Back forklift truck away from load; back-up alarm will sound when transmission direction selector is placed in reverse (R) position.
- (d) If load is to be deposited at a higher level than transport level or for stacking, move mast into vertical position and raise load to necessary height before moving load into position for lowering.

2-10. PREPARATION FOR MOVEMENT

CAUTION

Caution is advised when backing towing vehicle with the forklift attached. The short tow bar can cause the forklift to jackknife behind the tow vehicle and result in damage to the tow bar.

The forklift truck is towed rearward using the tow bar located on rear of truck.

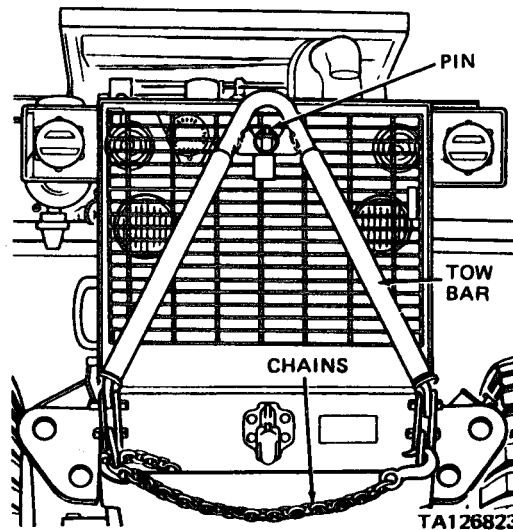

- a. Remove pin securing tow bar in position; lower tow bar into position and attach to towing vehicle.
- b. Unlatch each end of tow chains secured to truck and attach to towing vehicle.
- c. Pull AXLE DISCONNECT lever outward to disconnect axles for towing.

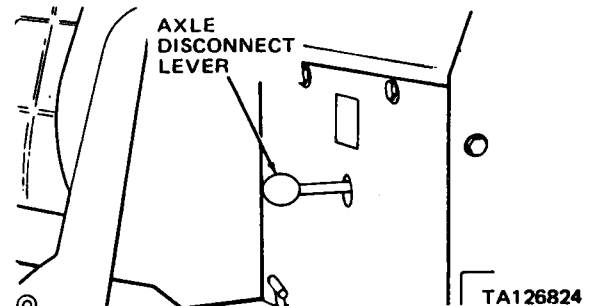

2-10. PREPARATION FOR MOVEMENT (cont).

d. Open (full counterclockwise) STEERING BYPASS valve.

e. Don't install shipping lock pin.

f. Don't tow forklift truck in excess of 35 MPH over improved roads. Reduce speeds as necessary to adapt to off-road/cross-country towing operations.

g. A trailing vehicle with warning, flashing, or hazard lights and a "Slow Moving Vehicle" emblem (NSN 9905-01-045-2201) is required behind the forklift truck to warn of a vehicle in tow.

2-11. OPERATING INSTRUCTIONS ON DECALS AND INSTRUCTION PLATES

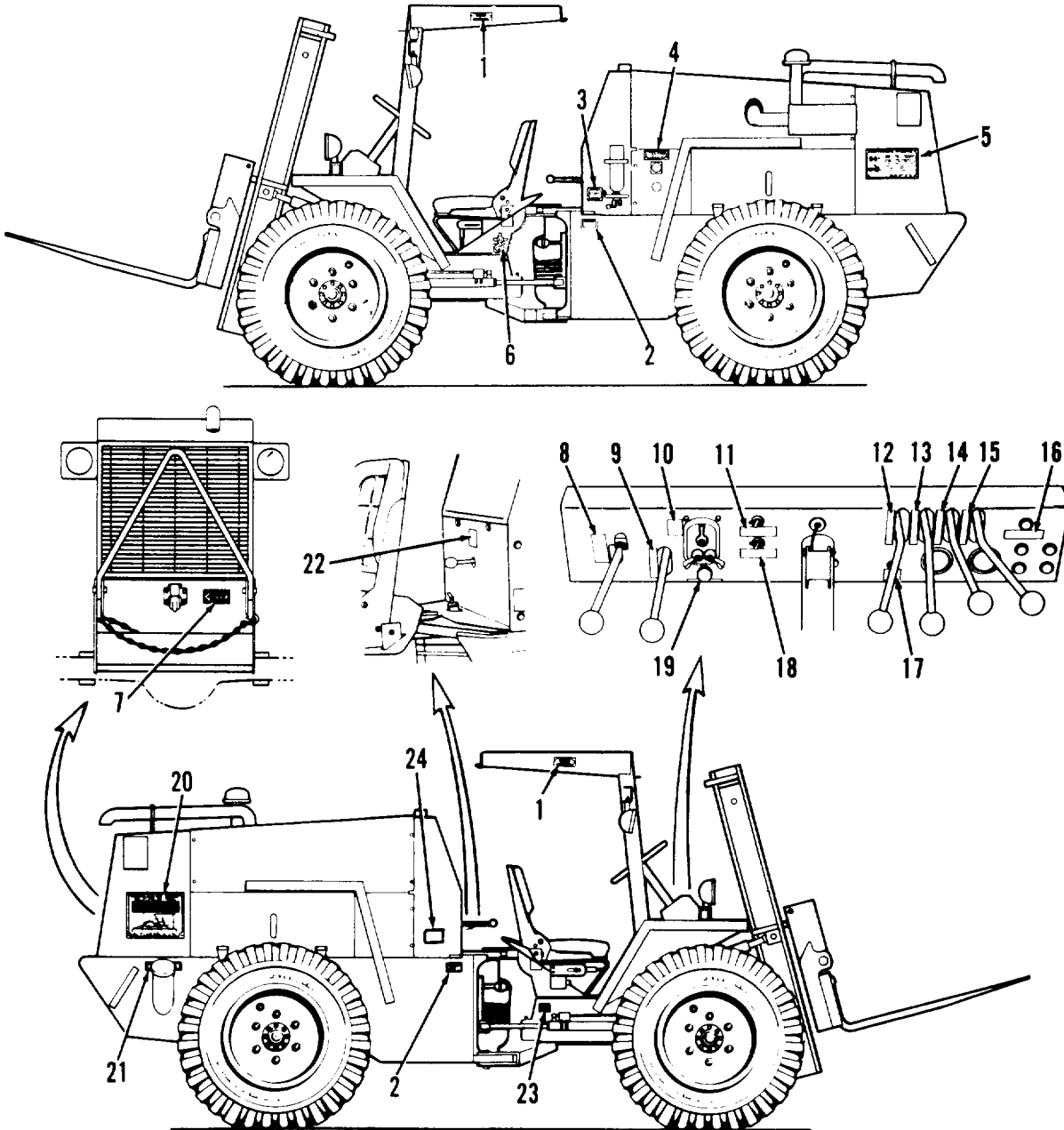

TA126825(1)

2-11. OPERATING INSTRUCTIONS ON DECALS AND INSTRUCTION PLATES (cont)

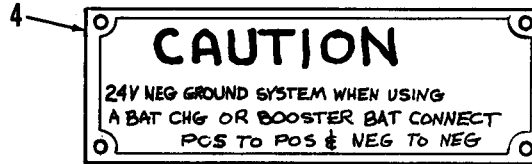
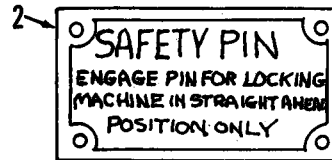

5 →

**MAINTENANCE SCHEDULE
MODEL M4K FORKLIFT**

ITEMS	INSTRUCTIONS	NOTES
AFTER EVERY 10 HOURS OR DAILY		
1. ENGINE CRANKCASE OIL DIPSTICK & FILLER	CHECK LEVEL ADD IF REQD	SEE CHART
2. HYDRAULIC OIL RESERVOIR FILL	CHECK LEVEL ADD IF REQD	SEE CHART
3. COOLANT LEVEL	CHECK LEVEL ADD IF REQD	1/2 WATER & 1/2 ETHYLENE GLYCOL
4. FUEL TANK FILLER	CHECK AND FILL DAILY	SEE TECHNICAL MANUAL
5. ROTATION BEARING	GREASE	MIL-G-10924
6. REAR AXLE TRUNNION PIN	GREASE	MIL-G-10924
7. BRAKE PEDAL PIVOT SHAFT	GREASE	MIL-G-10924
8. FORK CARRIER SIDESHIFT ROD & PAD	GREASE	MIL-G-10924
AFTER EVERY 30 HOURS OR WEEKLY		
9. UNIVERSAL JOINTS & SLIP YOKE	GREASE	MIL-G-10924
10. CENTER JOINT PIVOT	GREASE	MIL-G-10924
11. FRONT SHAFT SUPPORT BEARING	GREASE	MIL-G-10924
12. TILT CYLINDER PIVOT	GREASE	MIL-G-10924
13. STEERING CYLINDER PIVOT	GREASE	MIL-G-10924
14. BRAKE MASTER CYLINDER	CHECK LEVEL ADD IF REQD	SEE 175°C BRAKE FLUID
15. TRANSMISSION OIL DIPSTICK AND FILLER	CHECK LEVEL ADD IF REQD	SEE CHART
16. FUEL FILTER IN-LINE	REPLACE	SEE TECHNICAL MANUAL
AFTER EVERY 100 HOURS OR SEMI-MONTHLY		
17. ENGINE CRANKCASE OIL	CHANGE	SEE CHART
18. ENGINE OIL FILTER	REPLACE	MIL-G-10924
19. ROTATING CYLINDER	GREASE	MIL-G-10924
20. MAST PIVOT	GREASE	MIL-G-10924
AFTER EVERY 250 HOURS OR MONTHLY		
21. BATTERY	CHECK LEVEL ADD IF REQD	DISTILLED WATER
22. DIFFERENTIAL OIL FRONT AND REAR	CHECK LEVEL ADD IF REQD	SEE CHART
AFTER EVERY 500 HOURS		
23. FIRST AND SECOND STAGE FUEL FILTER	REPLACE	SEE CHART
24. TRANSMISSION OIL FILTER	CHANGE	SEE CHART
25. TRANSMISSION OIL FILTER	REPLACE	SEE TECHNICAL MANUAL
26. TRANSMISSION SUCTION SCREEN	CLEAN	SEE TECHNICAL MANUAL
AFTER EVERY 1000 HOURS		
27. HYDRAULIC OIL RESERVOIR	CHANGE	SEE CHART
28. HYDRAULIC OIL FILTER	CHANGE	SEE TECHNICAL MANUAL
29. HYDRAULIC SUCTION SCREEN	CLEAN	SEE TECHNICAL MANUAL
30. HYDRAULIC TANK BREATHER	REPLACE	MIL-L-2104 GRADE 30
31. MAST CHAINS	LUBRICATE	SEE CHART
32. DIFFERENTIAL OIL FRONT AND REAR	CHANGE	SEE CHART

LUBRICATION CHART

	AIR TEMPERATURE RANGES			
	ABOVE 32°F	10°F TO 32°F	30°F AND LOWER	0°F AND LOWER
ENGINE CRANKCASE	MIL-L-2104 GRADE 30	MIL-L-2104 GRADE 20	MIL-L-2104 GRADE 15	MIL-L-2104 GRADE 10
FRONT AND REAR DIFFERENTIAL HOUSING	MIL-L-2104 GRADE 30 GEAR LUBRICATION		MIL-L-2104 GRADE 30 GEAR LUBRICATION	
HYDRAULIC SYSTEM TRANSMISSION	MIL-L-2104 GRADE 10 HYDRAULIC AND TRANSMISSION FLUID			

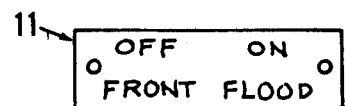
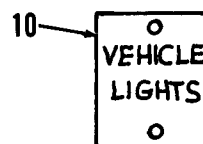
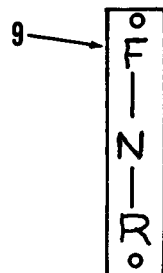
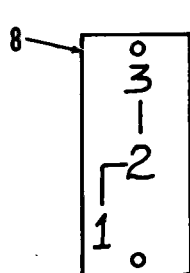
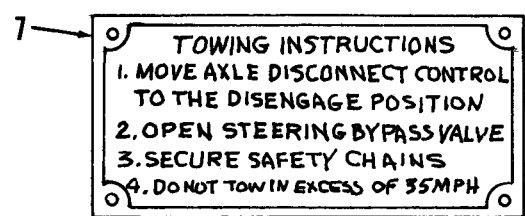
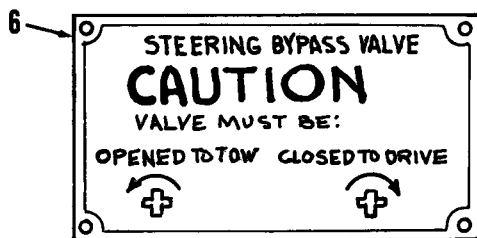

2-11. OPERATING INSTRUCTIONS ON DECALS AND INSTRUCTION PLATES (cont)

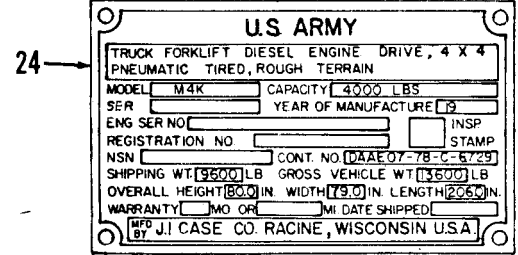
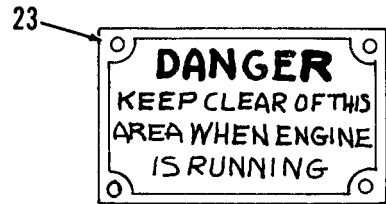
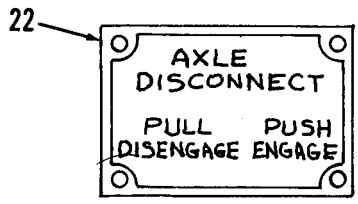
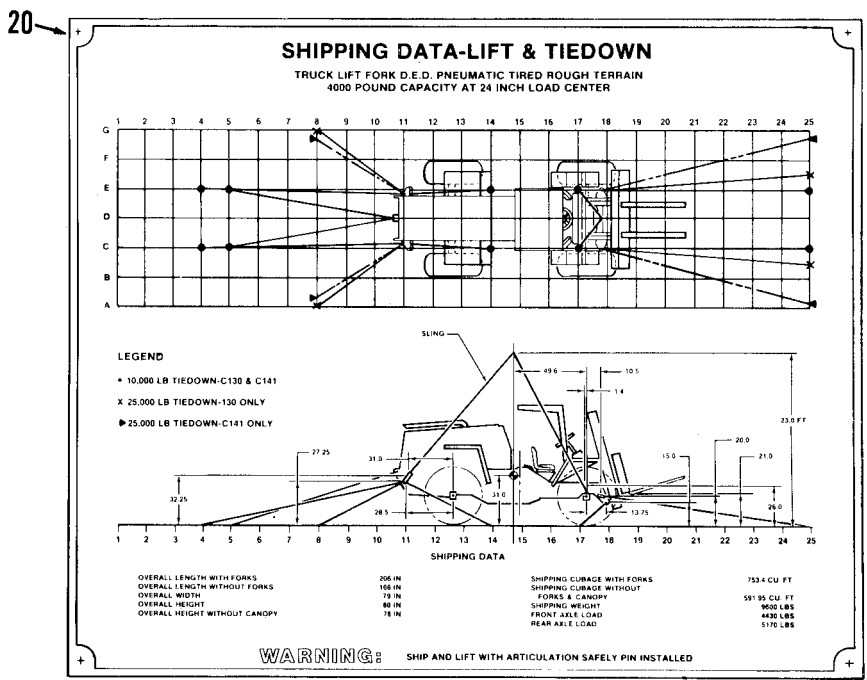
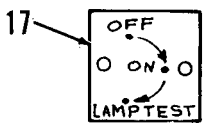
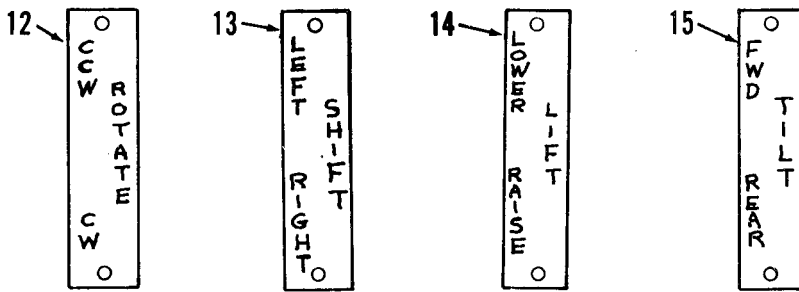

Section IV. OPERATION UNDER UNUSUAL CONDITIONS

	Para		Para
Operation in Unusual Weather	2-12	Operation at High Altitudes	2-15
Operation in Dusty or Sandy Areas	2-13	Operation in Snow	2-16
Operation in Salt Water Areas	2-14	Fording	2-17

12-12. OPERATION IN UNUSUAL WEATHER

a. Extreme Cold

(1) General. Extensive preparation of the vehicle is required when extreme cold weather is anticipated. Extreme cold causes lubricants to thicken or congeal, presents a risk of freezing batteries and diminishes their electrical efficiency, can crack electrical insulation to cause short circuits, prevents fuel from vaporizing readily to form the combustible mixture necessary for starting, causes various materials to become hard, brittle, and easily damaged. You must make sure the cooling system has been filled with the appropriate anti-freeze solution to protect the system against sub-freezing temperatures.

(2) Cooling System. Before the cooling system is drained and filled, inspect the system for leaks and general condition. All deteriorated or damaged hoses must be replaced. Make sure that all clamps are tight and that drain cocks are properly closed. When anti-freeze is added to the cooling system, be sure ample space is allowed for the required amount of anti-freeze required. Be sure you operate the engine for 15 minutes to allow the solution to properly mix.

(3) Lubrication. Be sure that the correct grade of lubricant is applied to the lubrication points. If necessary, drain and refill if the lubricant grade is not correct for cold weather operation.

(4) Fuel System. Be sure precautions are taken to eliminate water and moisture from the fuel system by draining and flushing the fuel tank, draining off any water from the fuel tank and filters at the end of each day's operation, replacing the fuel filter elements, and completely filling the fuel tank after each operating period to avoid water condensation. The fuel tank must not be allowed to remain partially empty over long periods of time and all ice and snow must be completely removed from around the filler opening before refilling the fuel tank.

(5) Engine Operation.

- (a) Use the cold weather starting aid to start the engine.
- (b) Run the engine at reduced speed only long enough to circulate the oil through the

engine, then increase speed and warm up the engine. Low idling speeds during extremely cold temperatures can result in incomplete combustion and heavy deposit formations on the valves.

- (c) Cover the radiator if necessary to bring engine up to operating temperature.
- (6) At Halt or Parking.
- (a) Park vehicle in sheltered place if possible. Cover to protect engine, accessories, and controls from ice and snow.
 - (b) Run vehicle onto planks to 'prevent tires from freezing to the ground. Block up forks.
 - (c) Be sure you clean wet snow or mud from tires and cylinders before it freezes.
 - (d) In extremely cold weather, remove the batteries and store them in a moderately warm area. Reinstall the batteries just before you start the engine.

b. Extreme Heat.

(1) General. Check temperature light frequently for indication of overheating. Allow engine to idle slowly when it is overheated until temperature is reduced indicated by light going out.

(2) Cooling System.

- (a) Drain, flush, and refill cooling system.
- (b) Check coolant level at frequent intervals and keep radiator cap tight.
- (c) Be sure the radiator is free of bugs, dust, and other foreign matter.
- (d) Check fan belt tension frequently.

(3) Lubrication. Lubricate the vehicle with correct grade of lubricants in accordance with the lubrication chart. Change filter elements at shorter intervals than normal.

(4) Air Cleaner. Service air cleaner at shorter than normal intervals.

(5) At Halt or Parking. Park the vehicle in a shaded area if possible.

c. Rainy or Humid Conditions. Keep vehicle protected when not in use. Dry off seat and wiring to prevent formation of mildew. Keep fuel tank full. Service filters more frequently than normal. Keep all moving parts well lubricated.

2-13. OPERATION IN DUSTY OR SANDY AREAS

a. General. Sand and dust are abrasive and can cause wear on many parts of the vehicle. Airborne sand and dust can clog the radiator and air cleaner.

b. Cooling System. Be sure you check the radiator frequently and keep air passages open.

c. Air Cleaner. Reduce service intervals for the air cleaner and clean the air cleaner as often as necessary.

d. Lubrication. Lubricate the vehicle at more frequent intervals. Clean all fittings and lubrication openings thoroughly before lubricating to prevent entry of dust or sand with the lubricant. Take care to prevent contamination of lubricants with dust or sand.

e. Tire Pressure. When operating the vehicle on soft sand at slow speeds (not exceeding 10 MPH), the tire inflation pressure may be decreased to 30 PSI for improved traction.

CAUTION

When operating in excess of 10 MPH or on hard surface terrain or roads, the standard inflation pressure of 45 PSI must be maintained.

f. At Halt. When the vehicle is not in use, cover the operator's compartment, and utilize what ever means are available to protect the engine compartment from the entry of windblown dust or sand.

g. Mast Assembly. Periodically check inner channel of inner mast and bottom two rollers on carriage bearing plate (part of side shifter frame) for build-up of dust, dirt, or sand. Use wire brush to remove dust, dirt, or sand build-up.

2-14. OPERATION IN SALT WATER AREAS

Keep vehicle as clean as possible; after use, wash with fresh water. Keep all lubrication points clean and well

lubricated. Keep all wiring and connections clean and free from corrosion.

2-15. OPERATION AT HIGH ALTITUDES

Keep a constant watch on coolant level. Add coolant if necessary. Keep close watch on engine instruments during operation.

NOTE

Engine will operate at less than peak performance at high altitudes.

2-16. OPERATION IN SNOW

Keep fuel tank full and snow and ice away from fuel filler when servicing the vehicle. Clean snow from operating controls and indicators and from operator's seat.

2-17. FORDING

The vehicle may safely be subjected to depths up to 20-inches. Observe the following when fording any body of water:

a. Before Fording. Check depth of the water, allowing for the consistency of the bottom. Don't attempt to ford even the narrowest stream more than 20-inches deep. Make sure the engine is operating at full efficiency before fording.

b. During Fording. Shift the transmission in the low-speed range and speed up the engine to minimize the danger of stalling. Enter the water slowly to minimize surges of backwash into the engine compartment. Speed must not exceed three to four MPH. If stalling or complete submersion occurs, notify organizational maintenance.

c. After Fording. Lubricate the vehicle completely, as soon as possible after fording.

CHAPTER 3 OPERATOR/CREW MAINTENANCE INSTRUCTIONS

CHAPTER OVERVIEW

The purpose of this chapter is to provide you with lubrication instructions and troubleshooting procedures to help you keep your equipment in good running order.

Index

Section	Title	Page
I	Lubrication Instructions	3-1
II	Operator/Crew Troubleshooting Procedures	3-3

Section I. LUBRICATION INSTRUCTIONS

	Para
General Lubrication Information	3-1
Lubrication Information	3-2
Lubrication Requirements	3-3

3-1. GENERAL LUBRICATION INFORMATION

This section contains general lubrication instructions in addition to those included in the lubrication order.

3-2. LUBRICATION INFORMATION

a. Care of Lubricants. Keep all lubricants in clean, closed containers and store in a dry area away from external heat. Don't allow dust, dirt, or other foreign matter to mix with lubricants during storage or use. Keep all lubrication equipment clean and ready for use.

b. Cleaning. Keep all external parts that do not require lubrication free of lubricants. Wipe all dirt and other foreign matter from lubrication points using a clean cloth. Clean caps, covers, and plugs and surrounding area before removing them from the vehicle. Clean

lubrication points after lubrication to prevent accumulation of foreign matter.

c. Points of Lubrication. Refer to the lubrication order for lubrication points, and intervals of lubrication.

3-3. LUBRICATION REQUIREMENTS

a. For lubrication under normal conditions, refer to the lubrication order.

b. For instructions on lubrication in weather below zero degree F (-18 degrees C), refer to TM 9-207.

c. For lubrication before and after fording, refer to TM 9-238.

d. After operating in dusty or sandy conditions, clean and inspect all lubrication points. Lubricate vehicle in accordance with the lubrication order.

Section II. OPERATOR/CREW TROUBLESHOOTING PROCEDURES

	Para
General	3-4
Troubleshooting Table	3-5

3-4. GENERAL

a. The troubleshooting table (paragraph 3-5) lists common malfunctions which you may find during operation of the forklift truck. You should perform the tests/ inspections and corrective actions in the order listed.

b. This manual cannot list all malfunctions that may occur, nor all test or inspections and corrective actions. If a malfunction is not listed or is not corrected by listed corrective actions, notify your supervisor.

3-5. TROUBLESHOOTING TABLE

MALFUNCTION	TEST OR INSPECTION	CORRECTIVE ACTION
-------------	--------------------	-------------------

1. ENGINE WILL NOT CRANK

Step 1. Check if ignition switch is turned off.

Place ignition switch in ON position.

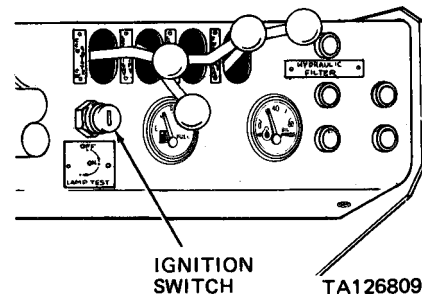

Step 2. Check that transmission direction selector is in neutral (N) position.

Place transmission direction selector in neutral (N) position.

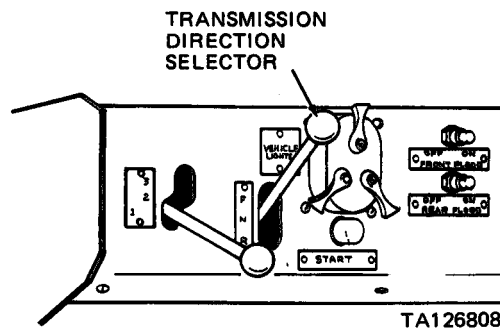

3-5. TROUBLESHOOTING TABLE (cont)

MALFUNCTION

TEST OR INSPECTION

CORRECTIVE ACTION

1. ENGINE WILL NOT CRANK (cont)

- Step 3. Remove pin holding tow bar in position and lower tow bar to ground. Move knob to left and open grille by swinging it to left. Rotate fasteners (located both sides of battery cover) and pull battery cover from rear of vehicle. Check for loose, corroded, or damaged battery cables and connections.

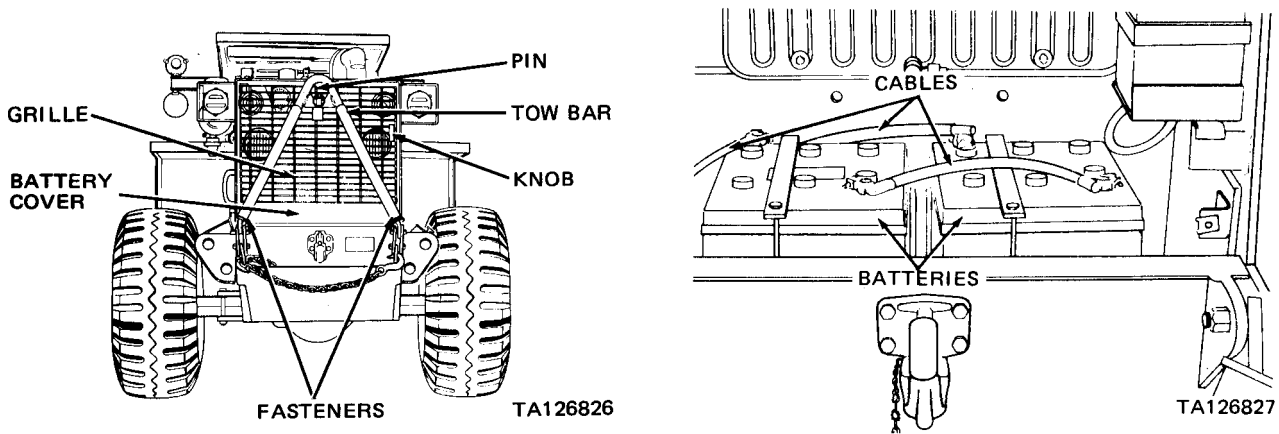

Clean corroded cables with clean water and a brush. Tighten loose connections and report damaged battery cables to organizational maintenance.

- Step 4. Remove left side panel from vehicle by pulling down on hook to disengage it from lock bracket. Grasp handle on left side panel and pull side panel from vehicle. Check cable connections to starter motor for looseness.

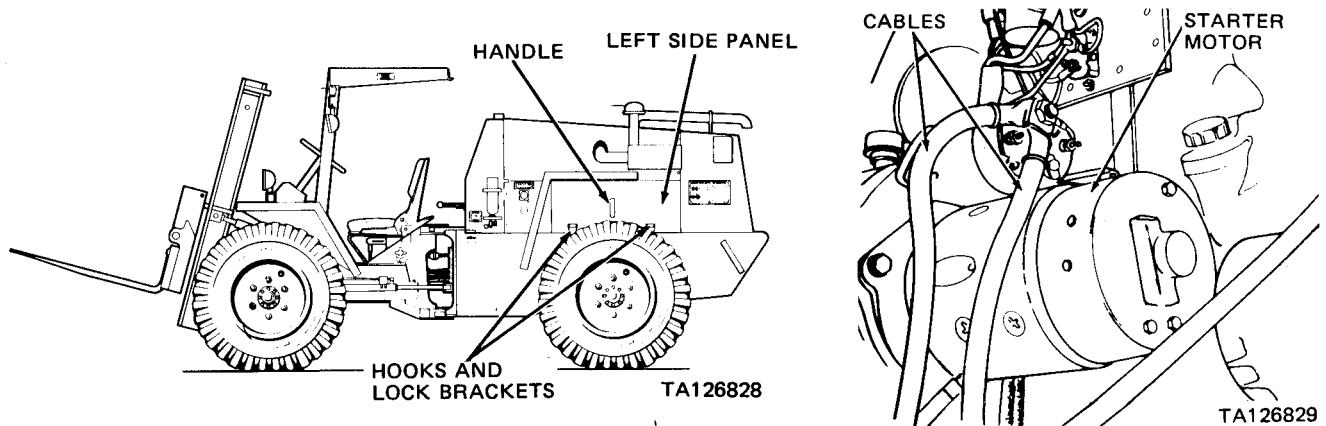

Tighten cable connections.

3-5. TROUBLESHOOTING TABLE (cont)

MALFUNCTION
 TEST OR INSPECTION
 CORRECTIVE ACTION

1. ENGINE WILL NOT CRANK (cont)

Step 5. Lower tow bar, open grille, and remove battery cover as described in step 3 above.

WARNING

Battery electrolyte is toxic and corrosive. Use protective goggles and gloves when performing the following. Avoid contact with skin, eyes, clothes, and don't breathe vapors.

Using a hydrometer and thermometer, check specific gravity of battery electrolyte in each cell. Refer to following figure:

To determine charge of a battery, hydrometer readings must be corrected to a temperature of 80 degrees F. The normal correction is 4 points (0.004) of gravity for each 10 degrees change in temperature above or below 80 degrees. Example: If the specific gravity reading is 1,280 at zero degree F, subtract 0.032 as shown in the figure below. The corrected reading in this case is 1,248.

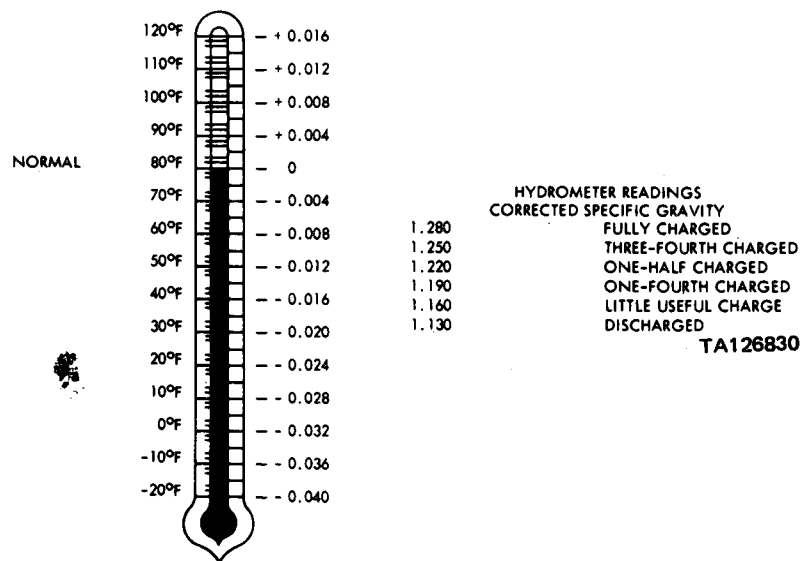

Notify organizational maintenance if a corrected specific gravity reading of less than 1.225 is obtained (battery must be recharged) or if specific gravity reading between cells differs by more than 25 points (0.025) (battery must be replaced).

3-5. TROUBLESHOOTING TABLE (cont)

MALFUNCTION
 TEST OR INSPECTION
 CORRECTIVE ACTION

2. ENGINE WILL NOT START OR IS DIFFICULT TO START

Step 1. Remove right side panel from vehicle by pulling down on hook to disengage it from lock bracket. Grasp handle on right side panel and pull side panel from vehicle.

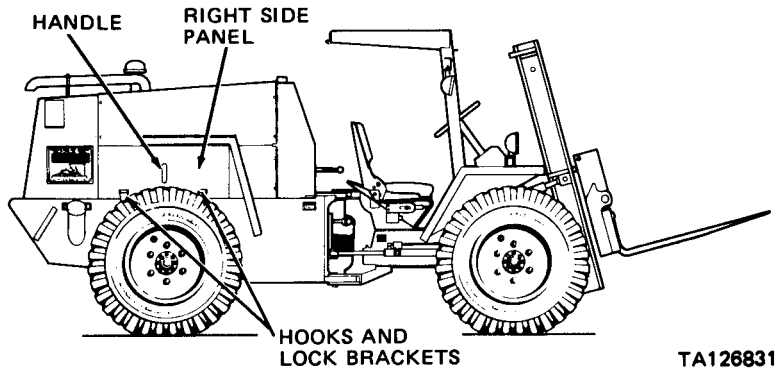

Check if fuel shut-off valve (located right side, in engine compartment above fuel filler neck) is in off position.

OFF

Place handle in on position.

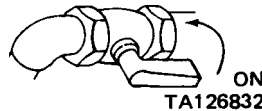

Step 2. Check if there is fuel in fuel tank.

WARNING

Diesel fuel is combustible.

Fill fuel tank.

Step 3. Lower tow bar, open grille, and remove battery cover as described in MALFUNCTION 1, step 3 above. Check for loose, corroded, or damaged battery connections and cables.

Clean corroded cable connections with clean water and a brush. Tighten loose connections and report damaged cables to organizational maintenance.

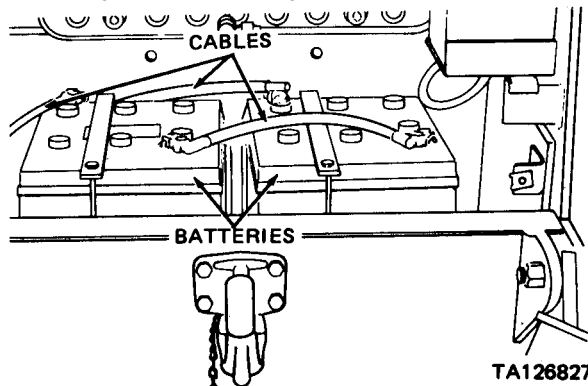

3-5. TROUBLESHOOTING TABLE (cont)

MALFUNCTION
 TEST OR INSPECTION
 CORRECTIVE ACTION

2. ENGINE WILL NOT START OR IS DIFFICULT TO STAR (cont)

Step 4. Check for clogged fuel filters (notify organizational maintenance).

Notify organizational maintenance.

3. ENGINE STARTS BUT WILL NOT RUN

Step 1. Remove right side panel as described in MALFUNCTION 2, step 1 above. Check that fuel shut-off valve (located right side, in engine compartment above fuel filler neck) is completely open.

Place valve handle in full on position.

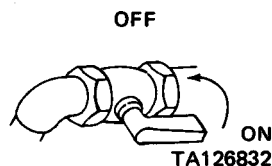

Step 2. Check if air cleaner indicator red flag is in view (indicates air cleaner is clogged).

Notify organizational maintenance.

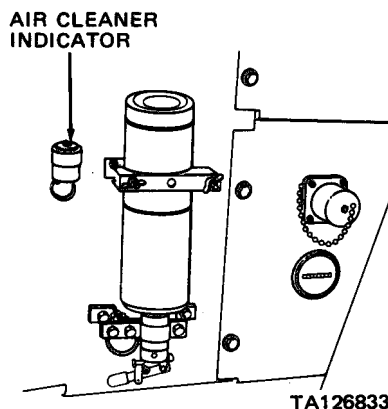

4. ENGINE STALLS FREQUENTLY OR DOES NOT DEVELOP FULL POWER

Step 1. Check if air cleaner indicator red flag is in view (indicates air cleaner is clogged).

Notify organizational maintenance.

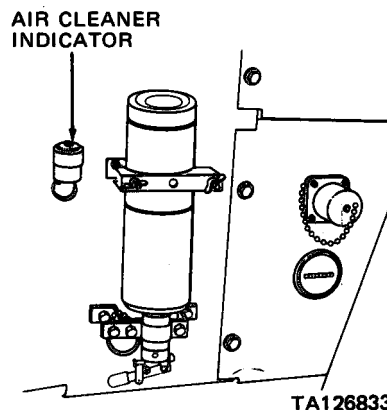

3-5. TROUBLESHOOTING TABLE (cont)

MALFUNCTION
TEST OR INSPECTION
CORRECTIVE ACTION

4. ENGINE STALLS FREQUENTLY OR DOES NOT DEVELOP FULL POWER (cont)

Step 2. Check for fuel contamination and condensation in fuel tank (notify organizational maintenance).

Notify organizational maintenance.

5. EXCESSIVE OIL CONSUMPTION

Remove left side panel as described in MALFUNCTION 1, step 4.
Check for oil leaks at oil filter.
Check for oil leaks at oil pan drain plug.

Notify organizational maintenance.

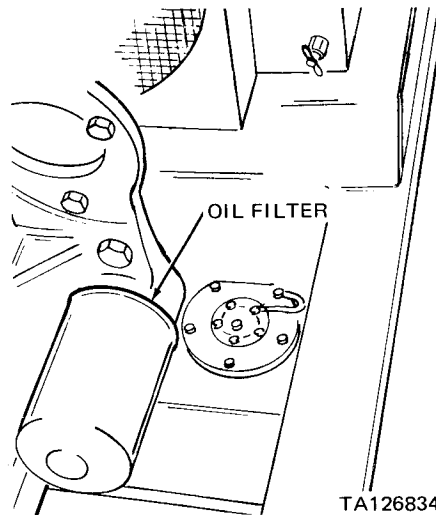

6. ENGINE OVERHEATS

Step 1. Lower tow bar and open grille as described in MALFUNCTION 1, step 3.
Check radiator for low coolant level and leaking condition.

Add coolant if necessary; refer leaking condition to organizational maintenance.

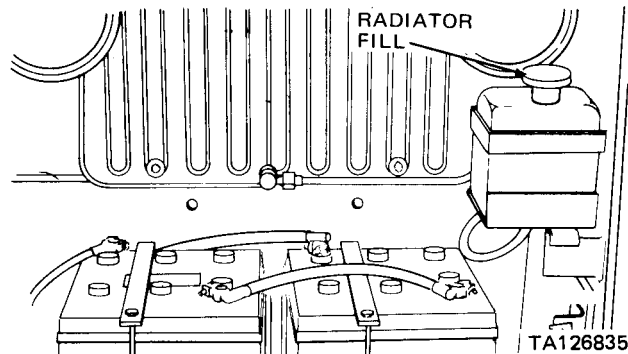

3-5. TROUBLESHOOTING TABLE (cont)

MALFUNCTION
 TEST OR INSPECTION
 CORRECTIVE ACTION

6. ENGINE OVERHEATS (cont)

step 2. Remove left and right side panels as described in MALFUNCTION 1, step 4 and MALFUNCTION 2, step 1, respectively.
 Check radiator hoses for leaking condition.

Notify organizational maintenance.

Step 3. Remove left and right side panels as described in MALFUNCTION 1, step 4 and MALFUNCTION 2, step 1, respectively.
 Check water pump for leaking condition.

Notify organizational maintenance.

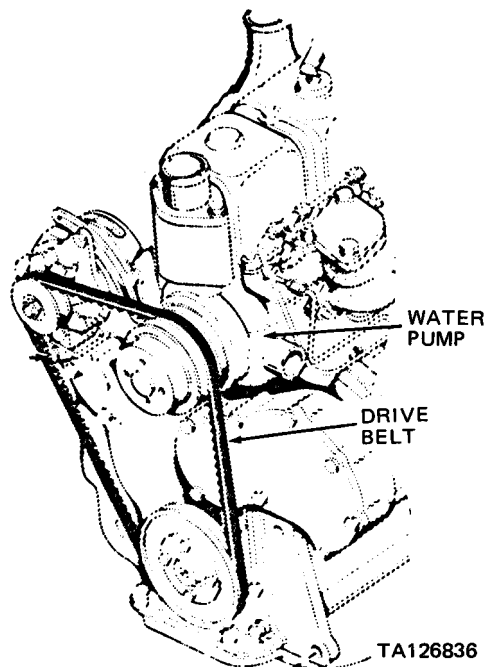

Step 4. Remove left and right side panels as described in MALFUNCTION 1, step 4 and MALFUNCTION 2, step 1, respectively.
 Check drive belt for proper tension (approximately 1/2 inch deflection).

Notify organizational maintenance.

7. EXCESSIVE ENGINE EXHAUST SMOKE

Check if air cleaner indicator red flag is in view (indicates clogged air cleaner).

Notify organizational maintenance.

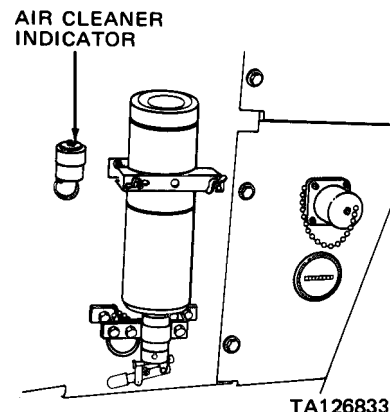

3-5. TROUBLESHOOTING TABLE (cont)

MALFUNCTION

TEST OR INSPECTION

CORRECTIVE ACTION

8. LOW ENGINE OIL PRESSURE

Step 1. Remove right side panel as described in MALFUNCTION 2, step 1
Check engine oil level.

Add engine oil if necessary.

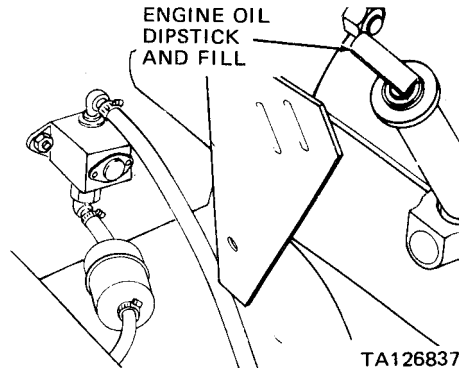

Step 2. Remove right side panel as described in MALFUNCTION 2, step 1. Check oil for dirty condition by removing dipstick, wiping between thumb and forefinger and noting if oil feels gritty and looks dirty.

Notify organizational maintenance.

Step 3. Remove right side panel as described in MALFUNCTION 2, step 1.
Check for loose or broken wire connection at oil pressure sender (located on right side of engine near fuel filters).

Connect loose wire; refer broken wire to organizational maintenance.

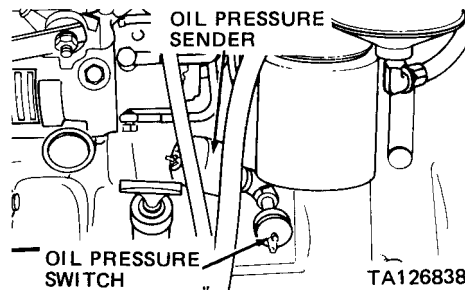

Step 4. Check for loose or broken wire on oil pressure gage (notify organizational maintenance).

Notify organizational maintenance.

3-5. TROUBLESHOOTING TABLE (cont)

MALFUNCTION

TEST OR INSPECTION

CORRECTIVE ACTION

9. BATTERY FAILS TO MAINTAIN CHARGE

- Step 1. Lower tow bar, open grille and remove battery cover as described in MALFUNCTION 1, step 3. Check level of battery electrolyte.

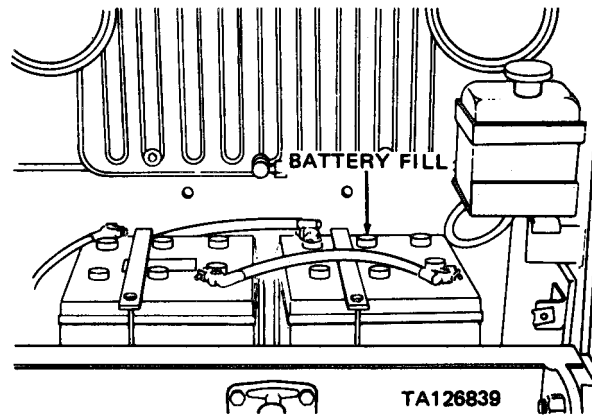

Fill with clean distilled water (enough to cover plates).

- Step 2. Lower tow bar, open grille and remove battery cover as described in MALFUNCTION 1, step 3. Inspect battery cables for worn or broken insulation, frayed or nicked wires.

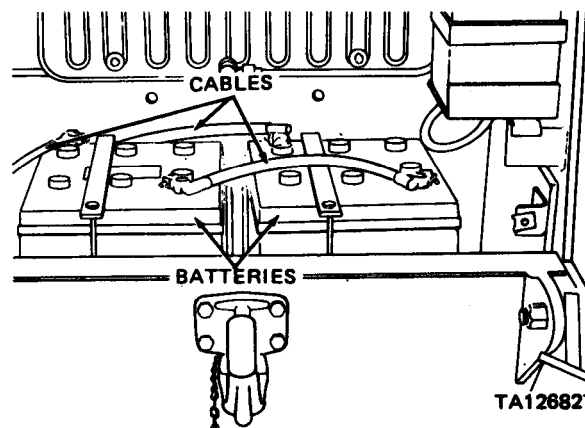

Tape worn or broken insulation; refer frayed or nicked wires to organizational maintenance.

- Step 3. Check for loose battery cables or broken battery terminals.

Tighten loose battery cables, refer broken battery terminals to organizational maintenance.

- Step 4. Inspect battery top and terminals for corrosion build-up.

Remove corrosion with clean water and a brush; clean terminals with a wire brush.

3-5. TROUBLESHOOTING TABLE (cont)

MALFUNCTION	TEST OR INSPECTION	CORRECTIVE ACTION
-------------	--------------------	-------------------

9. BATTERY FAILS TO MAINTAIN CHARGE (cont)

Step 5. Remove left and right side panels as described in MALFUNCTION 1, step 4 and MALFUNCTION 2, step 1, respectively.
Check tension of alternator drive belt (approximately 1/2 inch deflection).

Notify organizational maintenance.

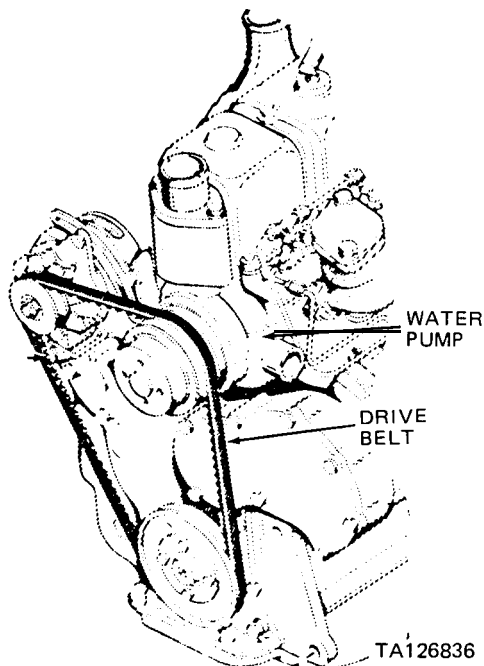

10. BATTERY REQUIRES FREQUENT FILLING

Remove left side panel as described in MALFUNCTION 1, step 4.
Check for loose connections at rear of alternator.

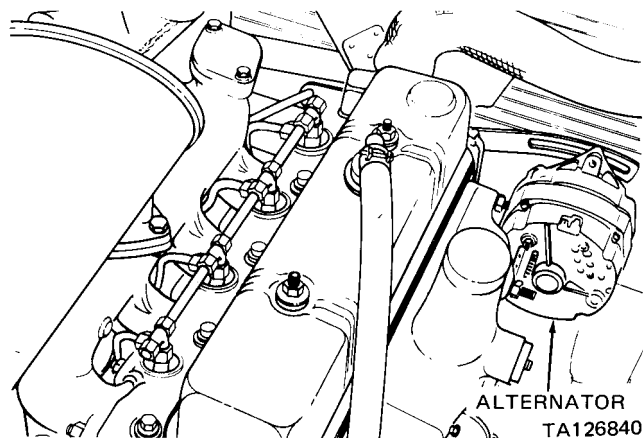

Notify organizational maintenance.

3-5. TROUBLESHOOTING TABLE (cont)

MALFUNCTION	TEST OR INSPECTION	CORRECTIVE ACTION
-------------	--------------------	-------------------

11. BRAKE PEDAL NOT AT LEAST TWO INCHES FROM FLOOR WHEN FULLY APPLIED

Step 1. Check hydraulic brake valve brake cylinder hydraulic fluid level (accessible through access hole located left side of operator's compartment, under seat).

Notify organizational maintenance.

Step 2. Check for fluid leakage at hydraulic brake valve.

Notify organizational maintenance.

12. VEHICLE WILL NOT TRAVEL

Step 1. Check if AXLE DISCONNECT lever is pulled outward (axles disconnected).

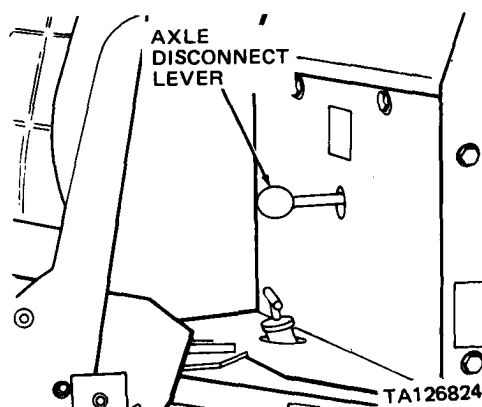

Push AXLE DISCONNECT lever inward.

Step 2. Remove left side panel as described in MALFUNCTION 1, step 4. Check transmission speed and direction selectors linkages for loose or missing parts at transmission control valve.

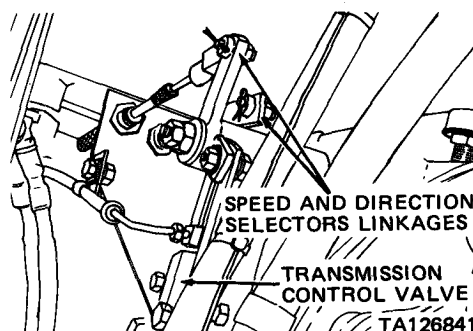

Notify organizational maintenance.

3-5. TROUBLESHOOTING TABLE (cont)

MALFUNCTION
TEST OR INSPECTION
CORRECTIVE ACTION

13. TRANSMISSION OVERHEATING

Step 1. Check transmission hydraulic fluid level for excessively high level.

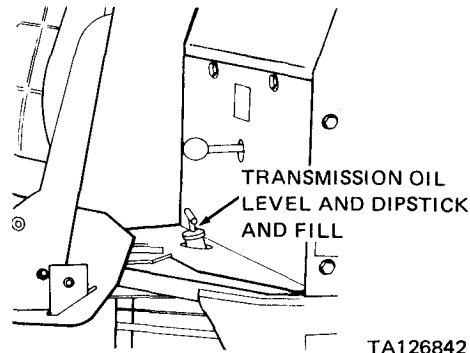

TA126842

Notify organizational maintenance.

Step 2. Lower tow bar and open grille as described in MALFUNCTION 1, step 3. Check oil cooler for accumulation of dust/dirt and foreign material on fins.

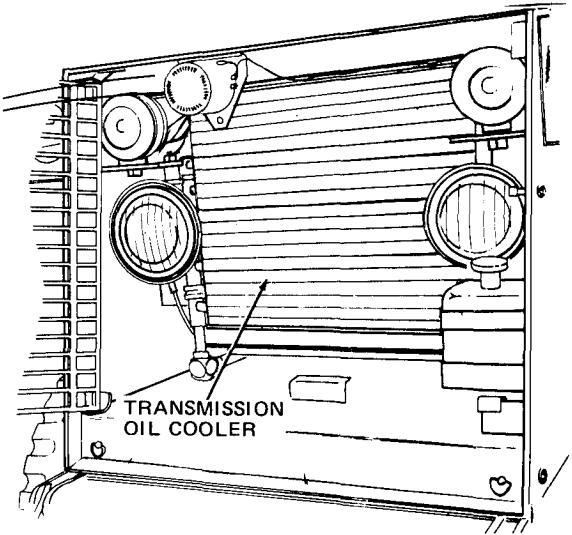

TA126843

Clean/remove all dust /dirt and foreign material.

14. PARKING BRAKE DOES NOT HOLD

Check for loose or damaged cable at parking brake lever.

Notify organizational maintenance.

3-5. TROUBLESHOOTING TABLE (cont)

MALFUNCTION
 TEST OR INSPECTION
 CORRECTIVE ACTION

15. HYDRAULIC LIFT SYSTEM DOES NOT OPERATE PROPERLY

- Step 1. Check hydraulic reservoir fluid level.
 Fill with hydraulic fluid to proper level.

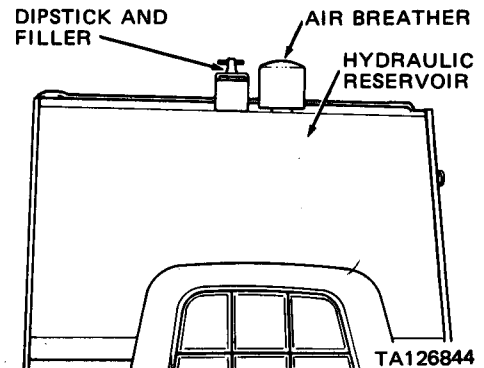

- Step 2. Check for leaks in hydraulic lines and fittings and at cylinders.
 Notify organizational maintenance.

16. STEERING SYSTEM NOT FUNCTIONING PROPERLY

- Step 1. Check hydraulic reservoir fluid level.
 Fill with hydraulic fluid to proper level.

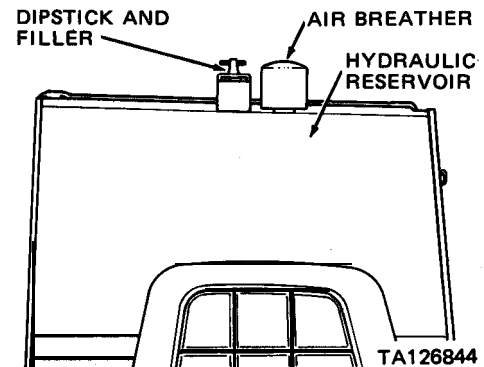

- Step 2. Check steering system lines for leaks; check steering cylinders for leaks.
 Notify organizational maintenance.

APPENDIX A REFERENCES

A-1. PUBLICATION INDEXES AND GENERAL REFERENCES

Indexes should be consulted frequently for latest changes or revisions of references given in this appendix and for new publications relating to material covered in this Publication.

- a. *Military Publication Indexes.*
 Consolidated Index of Army Publications and Blank Forms DA Pam 25-30
- b. *General References.*
 Dictionary-of United States Army Terms AR 310-25
 Authorized Abbreviations and Brevity Codes AR 310-50
 Operational Terms and Symbols FM 101-5-1
 Training in Units FM 25.3

A-2. OTHER PUBLICATIONS

The following publications contain information pertinent to the major item material and associated equipment.

- a. *Vehicle.*
 Truck, Forklift, DED, Pneumatic Tire, Articulated Frame Steer, 4,000 lb. Capacity, Rough Terrain,
 Army Model MHE 237 (J. I. Case Model M4K) LO 10-3930-638-12
- b. *Camouflage.*
 Camouflage FM 5-20
- c. *Decontamination.*
 NBC Decontamination FM 3-5
- d. *General.*
 Accident Reporting and Records AR 385-40
 Basic Cold Weather Manual FM 31-70
 Cooling Systems: Tactical Vehicles TM 750-254
 Manual for Wheeled Vehicle Driver FM 21-305
 Driver Selection and Training (Wheeled Vehicles) FM 55-30
 Mountain Operations FM 90-6
 Northern Operations FM 31.71

 Principles of Automotive Vehicles TM 9-8000
 Prevention of Motor Vehicle Accidents AR 385-55
 Procedures for Destruction of Tank-Automotive Equipment to Prevent Enemy Use TM 750-244-6
- e. *Maintenance and Repair.*
 Army Materiel Maintenance Policies AR750-1
 Use of Antifreeze Solutions and Cleaning Compounds in Engine Cooling System TB 750-651
 Color, Marking, and Camouflage Painting of Military Vehicles Construction Equipment, and
 Materials Handling Equipment TB 43-0209
- f. *Shipment and Limited Storage.*
 Administrative Storage of Equipment TM 740-90-1
 Packaging of Army Materiel for Shipment and Storage AR 746-1
 The Army Maintenance Management Systems (TAMMS) DA Pam 738-750

APPENDIX B

COMPONENTS OF END ITEM LIST

Section I INTRODUCTION

B-1. SCOPE

This appendix lists integral components of and basic issue items (BII) for the MHE 237 Forklift Truck to help you inventory items required for safe and efficient operation.

B-2. GENERAL

This Components of End Item List is divided into the following sections:

a. Section II - Integral Components of the End Item. These items, when assembled, comprise the Forklift Truck MHE 237 and must accompany it whenever it is transferred or turned *in*. The illustrations will help you identify these items.

b. Section III - Basic Issue Items. These are the minimum essential items required to place the MHE 237 Forklift Truck in operation, to operate it, and to perform emergency repairs. Although shipped separately packed, they must accompany the MHE 237 Forklift Truck during operation and whenever it is transferred between accountable officers. The illustrations will assist you with hard-to-identify items. This manual is your authority to requisition 'replacement BII, based on TOW/ MTOE authorization of the end item.

IB-3. EXPLANATION OF COLUMNS

a. Illustration (column (1)). This column is divided as follows:

(1) Figure number (sub-column (a)). Indicates the figure number of the illustration on which the item is shown.

(2) Item Number (sub-column (b)). The number used to identify item called out in the illustration.

b. National Stock Number (column (2)). Indicates the national stock number assigned to the item and which will be used for requisitioning.

c. Part Number (column (3)). Indicates the primary number used by the manufacturer, which controls the design and characteristics of the item by means of its engineering drawings, specifications, standards, and inspection requirements to identify an item or range of items.

d. Description (Column (4)). Indicates the Federal item name and, if required, a minimum description to identify the item.

e. Location (column (5)). The physical location of each item listed is given in this column. The list are designed to inventory all items in one area of the major item before moving on to adjacent area.

f. Usable on Code (column (6)). "USABLE ON" codes are included to help you identify which component items are used on the different models. Identification of the codes used in these lists are:

EXAMPLE:

Code	Used on
PAA	Model 114
PAB	Model 114A
PAC	Model 114B

g. Quantity Required (column (7)). This column lists the quantity of each item required for a complete major item.

h. Quantity (column 8)). This column is left blank for use during an inventory. Under the Rec'd. column, list the quantity you actually receive on your major item at a later date; such as for shipment to another site.

Section II. INTEGRAL COMPONENTS OF END ITEM

(1) Illustration		(2)	(3)	(4)	(5)	(6)	(7)	(8) Quantity			
(a) Fig. No.	(b) Item No.	National stock No.	Part number	Description	Location	Usable on code	Qty. req'd.	Rec'd.	Date	Date	Date

NONE

Section III. BASIC ISSUE ITEMS

(1) Illustration		(2)	(3)	(4)	(5)	(6)	(7)	(8) Quantity			
(a) Fig. No.	(b) Item No.	National stock No.	Part number	Description	Location	Usable on code	Qty. req'd.	Rec'd.	Date	Date	Date

NONE

APPENDIX C ADDITIONAL AUTHORIZATION LIST

Section I. INTRODUCTION

C-1. SCOPE

This appendix lists additional items you are authorized for support of the Forklift Truck MHE 237.

C-2. GENERAL

This list identifies items that do not have to accompany the Forklift Truck MHE 237 and that do not have to be

turned in with it. These items are all authorized to you by CTA, MTOE, TDA, or JTA.

C-3. EXPLANATION OF LISTING

National stock numbers, descriptions, and quantities are provided to help you identify and request the additional items you require to support this equipment.

Section II. ADDITIONAL AUTHORIZATION LIST

(1) National Stock Number	(2) Description Part Number and FSCM Usable on Code	(3) U/M	(4) Qty. Auth.
4210-00-775-0127	Extinguisher, Fire, Dry Chemical, 5 LB	EA	1

APPENDIX D

EXPENDABLE SUPPLIES AND MATERIALS LIST

Section I. INTRODUCTION

D-1. SCOPE

This appendix lists expendable consumable maintenance supplies you will need to operate and maintain the Forklift Truck MHE 237. These items are authorized to you by CTA 50-970, Expendable Items (Except Medical, Class V, Repair Parts, and Heraldic Items).

D-2. EXPLANATION OF COLUMNS

a. Column 1-Item Number. This number is assigned to the entry in the listing and is referenced in the narrative instructions to identify the material (e.g., "Use cleaning compound, item 11, App. F").

b. Column 2-Level. This column identifies the lowest level of maintenance that requires the listed item.
C-Operator/Crew

O-Organizational Maintenance
F-Direct Support Maintenance
H-General Support Maintenance

c. Column 3-National Stock Number. This is the National stock number assigned to the item; use it to request or requisition the item.

d. Column 4-Description. Indicates the Federal item name, and if required, a description to identify the item. The last line for each item indicates the part number followed by the Federal Supply Code for Manufacturer (FSCM) in parentheses, if applicable.

e. Column 5-Unit of Measure (U/M). Indicates the measure used in performing the actual maintenance function. This measure is expressed by a two-character alphabetical abbreviation (e.g., ea, in, pr). If the unit of measure differs from the unit of issue, requisition the lowest unit of issue that will satisfy your requirements.

Section II. EXPENDABLE SUPPLIES AND MATERIALS LIST

(1) Item Number	(2) Level	(3) National Stock Number	(4) Description	(5) U/M
			GAA, GREASE, AUTOMOTIVE AND ARTILLERY MIL-G-10924 (81349)	
1		9150-00-065-0029	2-1/4 OZ TUBE	EA
2		9150-00-935-1017	14 OZ CARTRIDGE	EA
3		9150-00-190-0904	1 LB CAN	EA
4		9150-00-190-0905	5 LB CAN	EA
5		9150-00-190-0907	35 LB PAIL	EA
			OIL, LUBRICATING, ENGINE, MIL-L (81349)	
6		9150-00-186-6689	1 QT CAN	EA
			OIL, HYPOID, SAE 90 MIL-L-2104C (81349)	
7		9150-00-577-8544	5 GAL CAN	EA
			CLEANING EQUIPMENT	
8		7920-00-291-5815	BRUSH, WIRE: Scratch, S-wire, Curved hdl, wire lg outside block: 1-1/8 to 1-1/4 in. 4 rows wide, 18 rows lg, 14 in lg	
9		7920-00-205-1711	RAGS, COTTON: Wiping	BL
10		6850-00-264-9038	SOLVENT: Dry Cleaning, Fed Spec PD-680, 1 Gal Can	EA
			GREASE: Wheel bearing, MIL-G-18709	
11		9150-00-663-9795	6.5 LB CAN	EA
			OIL, Hydraulic System, OE/HDO-10, MIL-L-2104C	
12		9150-00-189-6727	1 QT CAN	EA
13		9150-00-086-6668	5 GAL	EA
14		9150-00-191-2772	55 GAL	EA

INDEX

SUBJECT	PARAGRAPH (PAGE)	SUBJECT	PARAGRAPH (PAGE)
A		G	
Additional Authorization List		Gages	2-1a
Explanation of listing	C-3	General	3-4
General	C-2	General lubrication information	3-1
Scope	C-1	H	
Adjusting forks	2-9d(1)	Horn and back-up alarm	I-11b
After fording	2-17C	Hydraulic lift system does not operate properly	3-5
B		Hydraulic oil under pressure warning	(A)
Battery fails to maintain charge	3-5	I	
Battery requires frequent filling	3-5	Indicators	2-1b
Before fording	2-17a	Initial checks	2-8
Body, towing attachments, and towing controls	1-15	Instrument panel	2-1
Brake and throttle controls	2-2	L	
Brake pedal not at least two inches from floor when fully applied	3-5	List of abbreviations	1-6
Brake system	1-13	Location and description of major components	1-8
C		Low engine oil pressure	3-5
Capabilities and features	1-7b	Lubrication requirements	3-3
Components of end item list.....	B-3	Lubrication information	3-2
General	B-2	M	
Scope	B-1	Maintenance forms and records	2-6
D		Maintenance forms, records and reports	1-2
Dangerous chemicals warning	(A)	Mast assembly	1-16
Depositing load	2-9d(5)	Model number and equipment name.....	1-1b
Dry cleaning solvent warning	(B)	N	
During fording	2-17b	Noise hazard warning	(A)
E		O	
Electrical shock hazard warning	(A)	Operation at high altitudes	2-15
Electrical system	1-11	Operation in dusty or sandy areas	2-13
Engine overheats	3-5	Operation in salt water areas	2-14
Engine troubleshooting	3-5	Operation in snow	2-16
Equipment data	1-9	Operation in unusual weather.....	2-12
Equipment purpose, capabilities, and features.	1-7	Operating instructions on decals and instruction plates	2-11
Excessive engine exhaust smoke.....	3-5	Operating procedures	2-9
Excessive oil consumption.....	3-5	Operating the forklift	2-9d
Exhaust gases warning	(A)	Operator PMCS	T2-1
Externally mounted controls	2-4	Operator's compartment	2-3
Extreme cold (operation)	2-12a	Orientation	1-5
Extreme heat (operation)	2-12b	Other operator's controls and indicators	2-5
F		Other publications	A-2
Fire hazard warning	(A)		
Flood lights and engine switches	2-1d		
Fording	2-17		
Fork lift control levers	2-1f		
Fuel system	1-10		

INDEX

SUBJECT	PARAGRAPH (PAGE)	SUBJECT	PARAGRAPH (PAGE)
P			
Parking brake does not hold	3-5	Steering bypass valve warning	(B)
Picking up the load	2-9d(2)	Steering system	1-14
Preparation for movement	2-10	Steering system not functioning properly	3-5
Preventive maintenance checks and services . . .	2-7	T	
Publication indexes and general references . . .	A-1	Tilting load	2-9d(3)
Purpose of equipment	1-1c	Tire inflation warning	(A)
Purpose of forklift truck	1-7a	Transmission control levers	2-1c
R			
Rainy or humid conditions (operation)	2-12c	Transmission controls	1-12
Reporting equipment improvement recommendations (EIRs)	1-3	Transmission overheating	3-5
S			
Scope	1-1	Transporting load	2-9d(4)
Seat belt warning	(B)	Troubleshooting table	3-5
Speed warning	(B)	Type of manual	1-1a
Staring fluid warning	(B)	V	
Staring engine	2-9a	Vehicle lights	1-11a
Starting the forklift truck	2-9b	Vehicle lights switch	2-1c
		Vehicle will not travel	3-5
		W	
		Warranty information	1-4

RECOMMENDED CHANGES TO EQUIPMENT TECHNICAL PUBLICATIONS



THEN... JOT DOWN THE DOPE ABOUT IT ON THIS FORM. CAREFULLY TEAR IT OUT. FOLD IT AND DROP IT IN THE MAIL.

SOMETHING WRONG WITH THIS PUBLICATION?

FROM: (PRINT YOUR UNIT'S COMPLETE ADDRESS)

307th Aviation Company
APO New York 09185

DATE SENT

1 April 1980

PUBLICATION NUMBER

TM 10-3930-638-10

PUBLICATION DATE

May 1980

PUBLICATION TITLE

Truck, Forklift, DED,
4000 Lb, J.I. Cask M4K

BE EXACT PIN-POINT WHERE IT IS

PAGE NO	PARA-GRAPH	FIGURE NO	TABLE NO
2-5		PMCS	

IN THIS SPACE TELL WHAT IS WRONG AND WHAT SHOULD BE DONE ABOUT IT:

PMCS says to check my oil pressure gauge for normal readings. I have no oil pressure gauge in my vehicle. PMCS should be modified to reflect the configuration of my vehicle.

SAMPLE

PRINTED NAME GRADE OR TITLE, AND TELEPHONE NUMBER

SSG Chuck Rowst
A/cft Tech Insp

SIGN HERE

Chuck Rowst

DA FORM 2028-2
1 JUL 79

PREVIOUS EDITIONS ARE OBSOLETE.

P.S.--IF YOUR OUTFIT WANTS TO KNOW ABOUT YOUR RECOMMENDATION MAKE A CARBON COPY OF THIS AND GIVE IT TO YOUR HEADQUARTERS

SAMPLE

FILL IN YOUR
UNIT'S ADDRESS

FOLD BACK

DEPARTMENT OF THE ARMY

OFFICIAL BUSINESS

HQ US Army Tank-Automotive Materiel
Readiness Command
ATTN: DRSTA-MBS
Warren, Michigan 48090

TEAR ALONG PERFORATED LINE

RECOMMENDED CHANGES TO EQUIPMENT TECHNICAL PUBLICATIONS



THEN... JOT DOWN THE DOPE ABOUT IT ON THIS FORM. CAREFULLY TEAR IT OUT, FOLD IT AND DROP IT IN THE MAIL!

SOMETHING WRONG WITH THIS PUBLICATION?

FROM: (PRINT YOUR UNIT'S COMPLETE ADDRESS)

DATE SENT

PUBLICATION NUMBER

TM 10-3930-638-10

PUBLICATION DATE

May 1980

PUBLICATION TITLE

Truck, Forklift, DEC, 4000 Lb,
J.I. Case M4K

BE EXACT... PIN-POINT WHERE IT IS

PAGE
NO

PARA-
GRAPH

FIGURE
NO

TABLE
NO

IN THIS SPACE TELL WHAT IS WRONG
AND WHAT SHOULD BE DONE ABOUT IT:

PRINTED NAME, GRADE OR TITLE, AND TELEPHONE NUMBER

SIGN HERE

FILL IN YOUR
UNIT'S ADDRESS

FOLD BACK

DEPARTMENT OF THE ARMY

OFFICIAL BUSINESS

HQ US Army Tank-Automotive Materiel
Readiness Command
ATTN: DRSTA-MBS
Warren, Michigan 48090

TEAR ALONG PERFORATED LINE

RECOMMENDED CHANGES TO EQUIPMENT TECHNICAL PUBLICATIONS



THEN... JOT DOWN THE DOPE ABOUT IT ON THIS FORM, CAREFULLY TEAR IT OUT, FOLD IT AND DROP IT IN THE MAIL!

SOMETHING WRONG WITH THIS PUBLICATION?

FROM: (PRINT YOUR UNIT'S COMPLETE ADDRESS)

DATE SENT

PUBLICATION NUMBER TM 10-3930-638-10	PUBLICATION DATE May 1980	PUBLICATION TITLE Truck, Forklift, DED, 4000 Lb, J.I. Case M4K
--	------------------------------	--

BE EXACT . . . PIN-POINT WHERE IT IS				IN THIS SPACE TELL WHAT IS WRONG AND WHAT SHOULD BE DONE ABOUT IT:
PAGE NO	PARA-GRAPH	FIGURE NO	TABLE NO	

PRINTED NAME, GRADE OR TITLE, AND TELEPHONE NUMBER

SIGN HERE:

FILL IN YOUR
UNIT'S ADDRESS

FOLD BACK

DEPARTMENT OF THE ARMY

OFFICIAL BUSINESS

HQ US Army Tank-Automotive Materiel
Readiness Command
ATTN: DRSTA-MBS
Warren, Michigan 48090

TEAR ALONG PERFORATED LINE

RECOMMENDED CHANGES TO EQUIPMENT TECHNICAL PUBLICATIONS



SOMETHING WRONG WITH THIS PUBLICATION?

FROM: (PRINT YOUR UNIT'S COMPLETE ADDRESS)

DATE SENT

PUBLICATION NUMBER

TM 10-3930-638-10

PUBLICATION DATE

May 1980

PUBLICATION TITLE

Truck, Forklift, DED, 4000 Lb, J.I. Case M4K

BE EXACT PIN-POINT WHERE IT IS				IN THIS SPACE TELL WHAT IS WRONG AND WHAT SHOULD BE DONE ABOUT IT:
PAGE NO	PARA-GRAPH	FIGURE NO	TABLE NO	

PRINTED NAME, GRADE OR TITLE, AND TELEPHONE NUMBER

SIGN HERE

FILL IN YOUR
UNIT'S ADDRESS

FOLD BACK

DEPARTMENT OF THE ARMY

OFFICIAL BUSINESS

HQ US Army Tank-Automotive Materiel
Readiness Command
ATTN: DRSTA-MBS
Warren, Michigan 48090

TEAR ALONG PERFORATED LINE

By Order of the Secretary of the Army:

E.C. MEYER
General, United States Army
Chief of Staff

Official:

J. C. PENNINGTON
Major General, United States Army
The Adjutant General

Distribution:

To be distributed in accordance with DA Form 12-25A, Operator maintenance requirements for Truck, Fork Lift, Routh Terrain.

